



1

THE BMW 8 SERIES CONVERTIBLE



2

DESIGN AND HIGHLIGHTS

- 22 The Vision
- 24 Exterior design
- 26 Editorial "Design Thinking"
- 28 Editorial "Open up now!"
- 30 Interior design
- 32 Dynamics

3

INNOVATION AND TECHNOLOGY

- The Vision 38
- Driver assistance 40
- Connectivity and infotainment 41
- Comfort and functionality 42



4

EQUIPMENT

- 44 The Vision
- 46 BMW Individual
- 48 Exterior colour world
- 50 Interior colour world
- 54 Technical data

YOUR NEW SPEED DATING APP.

Download now the BMW Brochures app from your app store and discover driving pleasure!

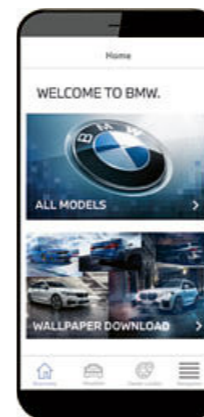

Let's talk about courage,
and why we need it more than ever.

Courage is independent and disruptive.
Courage questions, shatters and awakens.

We need bold, courageous voices.
All of us.
We need fresh thinkers with optimism.

We believe in the frontrunners.
The avantgarde, those who fight stagnation
and backwardness.

Courage only knows moving forward.
Driving the pioneers of our culture
to inspire tomorrow.

To create a sublime kind of new.
Reaching a superior level of excellence.

This is where a
new kind of luxury is born.



EMOTIONS CANNOT BE
TRAINED, NOR FORCED.
EMOTIONS ARE ROUSED –
BY A PLAY OF LIGHT AND
SHADOW, OF LINES
AND SURFACES.





WHO LOOKS FOR FREEDOM,
LEAVES BEHIND WHAT IS OLD.
WHO DARES, EXCEEDS LIMITS,
WITHOUT LOOKING BACK.
BECAUSE FORWARD DRIVE
IS AN ATTITUDE.

UNBUNDLED,
UNCOMPLICATED,
INDEPENDENT – WITH
THE RIGHT ATTITUDE,
EXPECTATIONS
ARE ONLY
STARTING LINES.







IT IS THE ATTENTION TO
THE SPECIAL THAT IMPARTS
PERFECTION TO EVERYTHING.
THE LOVE FOR DETAIL:
THE EPITOME OF PERFECTION.



SINCERITY IS NOT
MEASURED BY OPINIONS. BUT BY
THE ABILITY TO GET YOURSELF
EXCITED. BY DESIGN.
BY MATERIAL. BY THE MOMENT.



CULTIVATED POWER.
ELEGANT PRECISION.
EUPHORIA THAT
OUTSHINES
EVERYTHING.



2

LUXURY MUST AROUSE EMOTIONS.

Searching and finding modern perfection: Adrian van Hooydonk, chief designer at the BMW Group, on the new appearance in the segment of the most exclusive vehicles.

The models under the name Bayerische Motoren Werke open up a new world within the BMW portfolio. What is your idea of contemporary luxury?

We do not want to tell our customers how they should define luxury for themselves, but just want to make an attractive, diverse offer. The perception of luxury is very different worldwide. But a central aspect that becomes visible everywhere is the increasing significance of personal time. It is becoming the most valuable asset in a globalised world.

How is the wish for perfection and refinement expressed in mobility?

In today's mobile world, we spend more and more time in various modes of transport. Cars are now like personal rooms on wheels. One wants to feel completely comfortable in them. A steering wheel that you touch, the materials

that surround you have to feel perfect and the eye does not want to be disturbed by unclear lines or individual components. The interior of a vehicle is seen as a living space. It is about being surrounded by the highest possible sensuous quality.

What is the biggest challenge in the external appearance?

Luxury must be reflected to the outside world in a matter-of-fact way. There is a beautiful term for it: sophistication. For designers – our team has more than 700 employees at four locations worldwide, who are encouraged through constant competition with each other in terms of ideas – this means that every detail counts. The design has to arouse strong emotions while expressing the highest quality and durability at the same time. In order to be able to spend every moment intensely, full of meaning and beauty. Therefore, we are building a luxury ecosystem, a model family. In various forms of expression: contemporary saloons, elegant and very sporty coupés, but also vehicles that offer very luxurious space.

In the new designs, a common factor is noticeable: the reduction of lines. Do you want to increase luxury by making luxury less apparent in the design?

In this way, the design becomes clearer, more modern and more emotional. An expressive surface play is in the foreground, and the dynamics are emphasised even more than before by the vehicle body. The few but very precise vehicle lines underline the graphic design of the surfaces. The vehicle body looks more powerful, refined and luscious with the lavish surfaces without losing the sportiness that is typical to BMW. This is possible only because we work out every feature of a vehicle individually. For a BMW, one should be able to identify at first glance what kind of experience one would have with it. Especially in our large and particularly luxurious vehicles, we attach great importance to a marked appearance and the maximum possible feel-good factor in the interior. It's about freedom – and the feeling of being at home in a BMW.



THE EXTERIOR DESIGN.

Dynamic elegance, open to the top: The exterior design of the BMW 8 Series Convertible combines sportiness, exclusive style and that certain something to create a charming overall appearance. Inspired by the BMW 8 Series Coupé, it combines its racing DNA with its very own, perfectly shaped character. Starting with the fascinating curve of the headlights through the flowing silhouette to the finale of the flat rear lights that underline the width: Everything on the BMW 8 Series Convertible makes you want the exhilarating feeling of freedom that makes every journey a unique experience.

SPORTY PRESENCE, FROM EVERY PERSPECTIVE: THE WIDE REAR.

The rear of the vehicle appears remarkably wide and powerful, which is particularly impressive when the softtop is open. The third rear light, which is integrated into the boot lid, also reduces the height effect visually and closes the rear harmoniously upwards.



THE BMW 8 SERIES CONVERTIBLE, WITH ITS ELONGATED SHAPE, LOOKS CAPTIVATING IN THE SIDE VIEW BOTH WHEN CLOSED AND OPEN. THE COMPACTLY CUT SOFTTOP CREATES A STRIKING, DISTINCT NOTCHBACK SILHOUETTE.

A VOYAGE OF DISCOVERY FOR THE EYE: DESIGN LINES.

Reduced, precise lines and an expressive surface play behind the rear tyres characterise the side view. Instead of the BMW typical bead line, two expressively drawn design lines characterise the picture: Based on the precisely crafted Air Breathers they draw the course of the airflow along the body and thus pay homage to power and speed.

FREEDOM AT THE PUSH OF A BUTTON: THE INNOVATIVE SOFTTOP.

Thanks to the new clamp technology, the black Softtop blends harmoniously into the dynamic lines of the vehicle. At the push of a button, it opens and closes electrically in approximately 15 seconds, even while driving at speeds of up to 50 km/h. One of the outstanding properties of this extremely high-quality softtop is its excellent noise insulation.





DESIGN THINKING.

Open to new experiences: Why the softtop reveals so much about the character of the BMW 8 Series Convertible.

There are actually no two opinions: The heart of a vehicle is its engine. And yet the look on the exterior allows much more than insights into the design and presence of an automobile. This is especially true for a model like the BMW 8 Series Convertible. Because the most important characteristic feature – the softtop – combines the luxury and innovation claims of the entire model.

Opening the softtop already feels like a staging experience: Completely without any noise and with precise movements, the softtop is folded and retracted under the softtop flap in leather look with decorative stitching. The movement resembles a carefully rehearsed choreography and takes place at a speed of up to 50 km/h in exactly 15 seconds. The complete softtop with the haptic, unique fabric lined in several layers weighs much less than previous designs, and it can be folded into the variable compartment in the boot in a particularly space-saving manner.



EVEN WITH THE SOFTTOP CLOSED, THE BMW 8 SERIES CONVERTIBLE FASCINATES WITH ITS FLOWING, ELONGATED SILHOUETTE.

The design follows a clear premise: The softtop underlines the sporty silhouette and the powerfully elegant lines of the BMW 8 Series. For a model with outstanding performance characteristics, it is not just a question of shape, nor just a question of material and technology innovation. It is all about performance, closed as well as when open: The instant, highly dynamic driving pleasure.

THE SOFTTOP IS FOLDED AND RETRACTED COMPLETELY WITHOUT ANY NOISE AND WITH PRECISE MOVEMENTS.

The result is also interior acoustics as in a coupé. The gentle, wind-swept silhouette creates an exceptionally comfortable driving experience – even at higher speeds. Luxurious sound scenery even when closed: The multi-layer design absorbs sound waves better than many fixed roof structures. An extremely low noise level for all passengers.

Exceptional design, uncompromising technology, luxurious ambience: Additional comfort features increase the pleasure of driving with the top down in the BMW 8 Series Convertible at all temperatures: The Air collar¹ releases warm air when needed around the front headrests and takes care of passengers' necks on cool days. The experience is made even more pleasant with heated armrests¹ in the door and centre console as well as a heated steering wheel.¹ Pure enjoyment of driving with the top down, regardless of weather and speeds – in the BMW 8 Series Convertible.

¹ Available as optional equipment.

The perfect interplay between these individual elements creates a new, particularly luxurious form of driving with the roof down: The BMW 8 Series Convertible provides not just instant enjoyment of openness and freedom, but a pleasure for all the senses.

OPEN UP NOW!

Skyscrapers, hideaways, convertibles: There is simply more to discover if we show ourselves openly. A tribute to the luxury of not having the roof at the right moment.

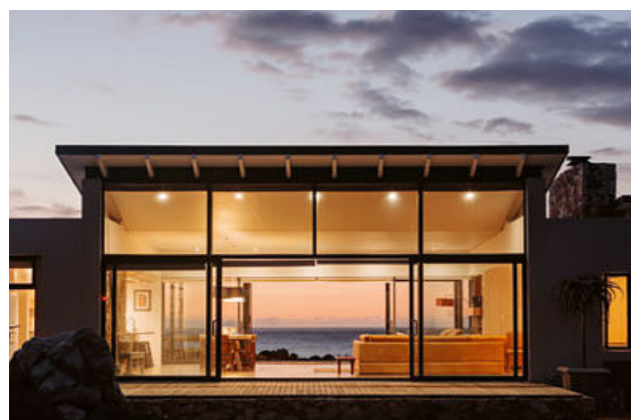

THE DESIRE FOR OPENNESS IS THE FREEDOM TO ENJOY A BROAD VIEW – THIS ATTITUDE IS SEEN EVEN IN THE HOMES WE BUILD.

These are exciting times. Never before has it been so easy to reach the unattainable, we can travel to the most remote places, experience unforgettable moments in the everyday here and now. The hunt for these moments is what drives us in life. To get rid of the superfluous, to take the liberty to get even more out of a situation. Set the personal viewing angle to panorama mode. At the touch of a button, you can feel the distance when the sky opens over the BMW 8 Series Convertible – much more than the mere interplay of finely tuned technology. It is an expression of being able to overcome boundaries. If we really aspire to it.

The new enthusiasm for this boundless freedom is evident in many areas. In luxury fashion, in haute cuisine, in architecture. Modern architects such as Jean Nouvel or the Japanese Pritzker prizewinner Shigeru Ban – known for his imposing, airy constructions – are currently creating spectacular buildings that have one thing in common: extremely transparent, opening roofs. Or they'll leave it out altogether. The sky as a roof. This new openness is no coincidence.

Spectacularly designed rooftops are the symbol for the reinterpretation of urban space. Long forgotten places of architecture – even some of the most spectacular buildings of the 20th century, such as the Guggenheim Museum in New York, did not

include large roof terraces. Today it's good manners for buildings to show themselves openly. There is evidence in every metropolis, from the many rooftop bars of East London to the spectacular roof terrace of the Mandarin Oriental in Barcelona. And some of the most interesting resorts and hideaways of this time completely do without the roof in their suites and place the perfect beds right on the floor – like in the middle of the Utah desert surrounded by violet shining canyons in the sunset. Or the Sky Suites of the AKA Central Park Hotel, downtown Manhattan, high above mountain village Goodman and MoMa. Sleep with maximum comfort in the open air – in the middle of the metropolis or in the middle of the wilderness.

OPENING THE SPACE ABOVE US IS NOT AN ESCAPE. IT IS AN ADVENTURE.

The common denominator is the basic idea that freedom and luxury can only be really felt and experienced when the world is open to you. It is the reason why convertibles fit so well into this time. Every trip in a BMW 8 Series Convertible gives you the feeling of being closer to the elements: to the air, to the sun. In combination with an absolute demand for performance and luxury. In the BMW 8 Series this means, for example: Ambient light and extremely high-quality glass applications in the interior. Exclusivity finds its absolute counterpart here. But the luxury of openness is also transformed in the BMW 8 Series Convertible from a quiet experience into an offensive one. It's the doubling of a trend. Supplemented by the speed factor.

Opening the space above us is not an escape. It's an adventure. The view upwards straightens the situation again, it shows: In the end, it's all about spending your time the way you want – not the way you have to. The fact that you can get much more out of this adventure at any time while driving opens up completely new dimensions. Long live freedom.



SPORTINESS, EXPRESSED IN ELEGANCE.

Freedom to the horizon: The interior reflects the extroverted sporty yet characteristically elegant character of the BMW 8 Series Convertible: Its consistent driver orientation is just as impressive as its sophisticated details, such as individually foldable rear seats for extended and even more flexible use of the luggage compartment. At the same time, remarkable design details such as the harmonious interior lighting or sparkling glass applications¹ on selected control elements create an atmosphere that spreads elegance and extravagance. The BMW 8 Series Convertible unfolds a unique world of dynamic luxury that fascinates anew every time you drive.

COMFORT IS THE BEGINNING OF ENJOYMENT: AIR COLLAR.

The Air collar¹ integrated in the height-adjustable front headrests ensures a pleasant climate even on cold days when driving with the top open thanks to a three-stage adjustable warm airflow.

ALSO LUXURY CAN BE EXPANDED: LEATHER 'MERINO' WITH EXTENDED CONTENTS.

The leather of the BMW Individual extended leather trim 'Merino'^{1,2,*} is already meticulously selected in the raw material selection, so that only absolutely flawless quality is used. It is completely dyed through without artificial embossing or surface treatment and immediately makes the highest demands on the interior feel-able and visible.



A HIGH-QUALITY GENUINE LEATHER LOOP ON THE BACK OF THE DRIVER AND FRONT PASSENGER SEATS ALLOWS THEM TO BE FOLDED FORWARD QUICKLY AND COMFORTABLY.

SPORTINESS, SUPPLEMENTED BY LUXURY – THE INTERIOR ALLOWS A DEEP INSIGHT INTO THE CHARACTER OF THE BMW 8 SERIES CONVERTIBLE.

AT THE CENTRE OF ATTENTION: DRIVER ORIENTATION.

In the cockpit of the BMW 8 Series Convertible, everything is aligned to the driver. Each control element is ergonomically placed exactly where it can be optimally reached. In that way, the driver has everything under control and can completely focus on the most important thing: absolute driving pleasure.

¹ Available as optional equipment.

² Standard for M850i xDrive.

* The availability of some equipment features and functions depends on engine variants or additional options. The market and production availability may vary. You can find detailed information about terms, standard and optional equipment at www.bmw.com or from your BMW Partner.





THE HEART OF PERFORMANCE:
THE BMW TWIN POWER TURBO 8-CYLINDER PETROL ENGINE.

The intelligent BMW xDrive all-wheel drive system with rear-wheel orientation provides permanent traction in all situations – because it distributes the drive torque fully variably to the axles before a wheel starts spinning. Despite the high-traction all-wheel drive, the driver of the BMW 8 Series Convertible does not need to do without the agility and precision of a rear-wheel drive vehicle: When cornering up to the vertex, the drive torque on the front wheels is significantly reduced, resulting in optimal feedback to the steering. When accelerating out of the curve, BMW xDrive transmits successive power to the front wheels, so that optimum traction is always created. The result of this power delivery is that the BMW 8 Series Convertible is practically catapulted into the subsequent straight.

MAXIMUM TRACTION BETWEEN CURVE AND STRAIGHT:
THE M SPORT DIFFERENTIAL.

Sportily into the curve – and just as sportily out of it: The M Sport differential^{1,2,*} of the BMW M850i xDrive Convertible, in combination with BMW xDrive, ensures maximum traction even in the case of dynamic driving and challenging routing. The result: excellent driving stability, even on demanding turns and in every road condition.

AT HOME ON THE RACE TRACK:
THE BMW 8 SERIES CONVERTIBLE
CONCEPTS HAVE COME DIRECTLY
FROM RACING EXPERIENCE.



RACING GENES MEET LOVE OF FREEDOM.

Ambitious. Independent. Thoroughly sporty. The racing genes that make this vehicle so unique can be felt in the BMW 8 Series Convertible right from the first few metres: The standard Adaptive M suspension lets you choose between dynamic or comfortable suspension tuning and ensures maximum control in every driving situation. Along with the specially-tuned BMW xDrive all-wheel drive and the regulated M Sport differential^{1,2,*}, maximum traction and maximum agility are offered even when accelerating out of corners. Here, Integral Active Steering^{1,2,*} provides additional stability without losing any dynamics at all and guarantees perfect steering and maximum speed confidence in every speed range – and it is a good thing, because the high body rigidity and the strengthened suspension components ensure a thrillingly direct implementation of each steering command. And if the brakes are used, the 19" M Sport brake^{1,2,*} delivers precisely controlled braking performance, which, in combination with the standard mixed performance tyres, ensures reliable deceleration. That is what freedom feels like!

390 kW

(530 hp) output

3.9 s

0 to 100 km/h

4.395 cm³

Capacity

750 Nm

Torque

CONFIDENT THROUGH EVERY CURVE – AT ANY SPEED:
ADAPTIVE M SUSPENSION PROFESSIONAL.

Highly agile, extremely comfortable: The Adaptive M suspension Professional^{2,*} combines typical dynamics with smoothness and stability. The electromechanical body roll stabilisation reduces the lateral inclination on the curves and thus enables very high cornering speeds. Depending on the situation, it distinguishes between a stabilising or agile driving behaviour. Thus, the driver can enjoy the fullest control and responsive handling even with fast cornering or quick changes of direction.

¹ Standard for BMW M850i xDrive.

² Available as optional equipment.

* The availability of some equipment features and functions depends on engine variants or additional options. The market and production availability may vary. You can find detailed information about terms, standard and optional equipment at www.bmw.com or from your BMW Partner.



THE ONLY ONE OF ITS KIND. WITH CLASSIC REAR-WHEEL DRIVE.

Something for purists: The BMW 840i Convertible is for those who appreciate the classic virtues of a sports car powered exclusively by the rear wheels. Connoisseurs do not want to do without this unique driving feeling – and experience it in this exceptional vehicle in an excitingly sporty way.

EXCITING SPORTS CAR FEELING. REINTERPRETED.

The new 840i engine of the BMW 8 Series Convertible makes the heart of every sports car enthusiast beat faster from the very first contact. Thanks to the BMW TwinPower Turbo 6-cylinder petrol engine, the entire power of this elegant vehicle is unleashed when the accelerator pedal is briefly pressed, catapulting this exceptional vehicle forward. Extremely sprint-friendly and confident up to high rev ranges, this engine shows the purest form of all qualities that make a BMW engine so extraordinary. Depending on the selected driving experience mode, the experience extends from dynamic to maximum sporty – a characteristic feature that becomes an experience even for the ears thanks to the unique sound of the BMW TwinPower Turbo 6-cylinder petrol engine.

POWERFUL AND DYNAMIC – WITH REAR-WHEEL DRIVE.

If you're looking for a pure sports car experience, choose the rear-wheel drive version: This is the only model in the 8 Series to transmit all the thrust of its powerful engine to the rear axle. Thanks to a lower total weight and an optimised weight distribution, this uncompromisingly sporty drive variant also ensures an exciting maximum of performance and dynamics. The pure experience of classic racing, euphorically interpreted – in the BMW 840i Convertible with rear-wheel drive. The new BMW TwinPower Turbo 6-cylinder petrol engine is available with BMW xDrive intelligent all-wheel drive, which combines sportiness and driving comfort.

250 kW

(340 hp) output

5.3 s

0 to 100 km/h

2.998 cm³

Capacity

500 Nm

Torque



CLASSY ROAD HOLDING IN EVERY SITUATION COMBINED WITH MAXIMUM FORWARD THRUST: THE BMW 840i DOMINATES EVERY STREET THAT IT TRAVELS ON.

EVERY TURN IS ANOTHER TRIUMPH:

The M Sport differential ensures that even with challenging changes of direction or on various surfaces, the engine power is optimally brought to the road. A permanent, continuously electronically controlled multi-disc lock, which was developed for motor sports, reduces any speed differences between the rear wheels and distributes the drive torque variably between them. Depending on the setting, this makes it possible to achieve a driving experience that covers the entire range from traction-oriented to maximum driving dynamics and sportiness – but ensures maximum driving pleasure in every respect.

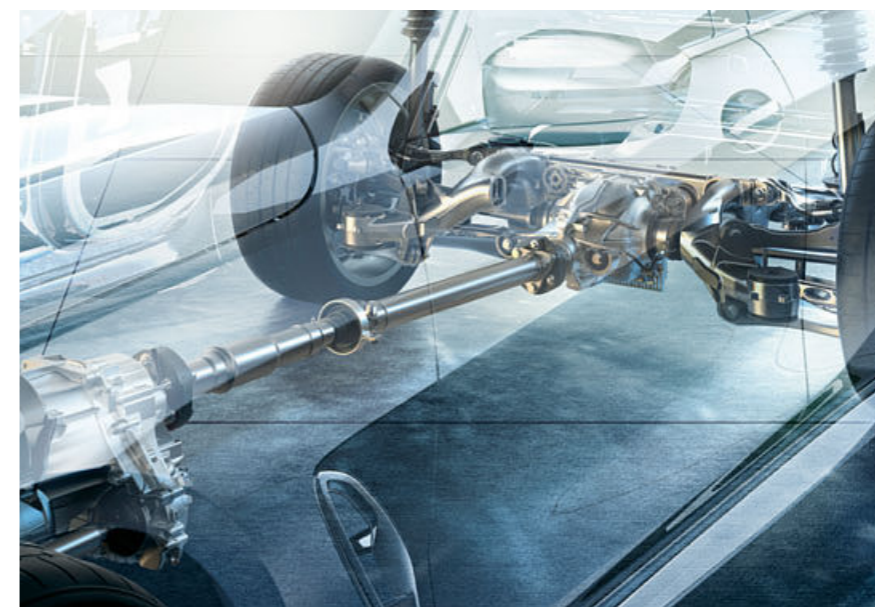

THE INCOMPARABLY PURE EXPERIENCE OF A CLASSIC REAR-WHEEL DRIVE – IN THE BMW 840i CONVERTIBLE, IT BECOMES EVIDENT AS TO HOW MUCH ADRENALIN THIS TYPE OF DRIVE GENERATES.



ADRENALINE – BROUGHT INTO SHAPE:
THE M CARBON EXTERIOR PACKAGE.

Carbon-fibre in every detail: The exclusive M Carbon exterior package¹* adds numerous design elements made of carbon-fibre to the already standard integrated carbon core components of the BMW 8 Series Convertible – for a more thoroughbred sports car look that draws everyone's attention. With mirror caps, air intakes, lateral spoiler elements in the front bumper, a decorative element around the tailpipe trims and a visually sharpened diffuser, the BMW 8 Series Convertible reinforces its motorsport character not only visually, but also substantially.

PERFORMANCE IN THE SOUND: THE SPORT EXHAUST SYSTEM.

Performance that you see, feel – and hear: The Sport exhaust system surrounds the driver with a powerful and rich engine sound from two twin tailpipes, which are integrated harmoniously into the rear apron. A genuine racing atmosphere – audibly also for all those who see the BMW 8 Series Convertible passing by. Thanks to the exhaust valve mechanism*, the pure, robust V8 sound can be adjusted to the driver's request at the touch of a button.



SPORTINESS
THAT YOU SEE,
HEAR AND FEEL ON
EVERY DRIVE.

ALWAYS 1ST PLACE: M SPORT SEATS FOR DRIVER AND FRONT PASSENGER.

The multi-adjustable M Sport seats with bucket seat character¹ and partly integrated headrest provide excellent lateral support for you and your front passenger. In addition, the backrest width can be individually adjusted. Their special design with black M logo highlights the vehicle's athletic capabilities.



FUNCTIONAL AND VISUAL HIGHLIGHT AT THE SAME TIME:
THE AIR BREATHER.

The precisely elaborated Air Breathers in the front fenders not only enhance the vehicle's aerodynamics, but also serve as a starting point of a course of striking design lines. Their interaction creates a powerful surface play that traces the air flowing along the vehicle.



A GAME OF
LINES AND SURFACES,
INSPIRED BY
LIGHT AND WIND.

¹ Available as optional equipment.
* The availability of some equipment features and functions depends on engine variants or additional options. The market and production availability may vary. You can find detailed information about terms, standard and optional equipment at www.bmw.com or from your BMW Partner.

3

EMOTION EXPRESSED AS INNOVATION.

Thoughts were born,
ideas thought through and
know-how taken to the extreme.
Innovative technologies were
developed, comfort and
efficiency enhanced and
performance levels increased.
But all this was not done to put
knowledge, ability and pioneering
spirit in the foreground –
but to make this one, special feeling
even more tangible:
Driving pleasure.
Technology becomes emotion –
Bayerische Motoren Werke.



DRIVING PLEASURE IN ITS PUREST FORM.

DRIVER ASSISTANCE

The intelligent assistants of BMW Personal CoPilot are available for every vehicle of the Bayerische Motoren Werke. These support you in all driving situations and increase safety and comfort. In this way, you ensure that you can look forward in a relaxed manner and devote yourself to the most important thing: sheer driving pleasure. Today, tomorrow and also in the future: The driver assistance systems in a vehicle from the Bayerische Motoren Werke define what is technically feasible – and as a reliable companion, ensure that you master every challenge with confidence.



IS THERE WHEN REQUIRED: DRIVING ASSISTANT PROFESSIONAL.

Driving Assistant Professional^{1,2} offers optimum comfort and maximum safety during lots of critical or monotonous driving situations with Steering and lane control assistant incl. support in narrow places, Emergency Stop Assistant, local hazard warning, Lane Keeping Assistant with active side collision protection and other safety functions.

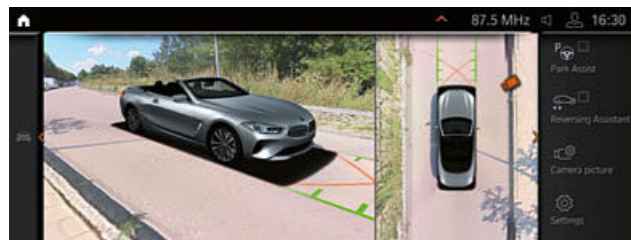

JOY EVEN WHEN PARKING: PARKING ASSISTANT PLUS.

Parking Assistant Plus^{1,*} makes parking and manoeuvring the vehicle easier. It features among others the Surround View system including Top View, Panorama View, Remote View 3D*, as well as a lateral parking aid, the Active Park Distance Control, emergency braking function, Parking Assistant with linear guidance and Reversing Assistant.



UNLIMITED CONNECTIVITY FOR INNOVATIVE INFORMATION.

CONNECTIVITY AND INFOTAINMENT



"HEY BMW": THE BMW INTELLIGENT PERSONAL ASSISTANT.

"Hello, BMW. Who are you?" Wouldn't it be incredible if your BMW acted like your personal assistant? Communicate in a new and easy way with your vehicle using the BMW Intelligent Personal Assistant^{1,*}. It knows you, learns your behaviours to improve every day and helps out whatever the situation. It can explain everything about your vehicle and help you get better acquainted with your BMW. You can even assign your own personal activation word.

To stand above it all and yet stay completely connected with your world: When it comes to connectivity and infotainment, Bayerische Motoren Werke does not want to follow any trends, but set standards. With BMW ConnectedDrive, you are optimally connected wherever you are, and you have access to the full range of communication, information and entertainment at any time. In addition, the personal mobility assistant BMW Connected also accompanies you on your smartphone outside the vehicle and supports you in your everyday life – because sheer driving pleasure starts long before you get in and does not stop when you get out of the car.

INNOVATIVE INFORMATION: BMW LIVE COCKPIT PROFESSIONAL WITH INNOVATIVE OPERATING CONCEPT.

This is luxury that is far ahead of its time: The Live Cockpit Professional is a display network consisting of a high-resolution instrument display with an impressive 12.3" screen diagonal behind the steering wheel and a 10.25" Control Display in the centre console. All information relevant to driving is displayed here in pin-sharp detail and a perfectly legible manner. The Live Cockpit Professional runs with the innovative BMW Operating System 7.0. This makes operation more convenient than ever: Whether via iDrive Touch Controller, touch operation on the Control Display, gestures or speech using the BMW Intelligent Personal Assistant – every function is available easily and intuitively.

ALWAYS UP TO DATE: REMOTE SOFTWARE UPGRADE

Do you want your BMW to be up to date with the latest software? With Remote Software Upgrade, your BMW will always be like new. Upgrades are installed over-the-air, just as they are for your smartphone. In this way, other functions in your vehicle can also be activated.

¹ Available as optional equipment.

² Function may be limited in darkness, fog or bright glare.

* The availability of some equipment features and functions depends on engine variants or additional options. The market and production availability may vary. You can find detailed information about terms, standard and optional equipment at www.bmw.com or from your BMW Partner.



Some ConnectedDrive Services may differ between countries. Please consult your local BMW partner for more information.

A WORLD OF ITS OWN. AND FOR YOU.

COMFORT AND FUNCTIONALITY

Vehicles from the Bayerische Motoren Werke not only stand for unlimited driving pleasure, but also for particularly sophisticated motoring enjoyment. Everything around you is designed for maximum comfort and maximum functionality. From atmospheric light design when entering the vehicle to the electric seat adjustment for an individually perfect seating position and lots of other equipment options: Everything here is designed to turn even an everyday trip into an extraordinary experience.

COMFORTABLE AT COOLER TEMPERATURES TOO: THE HEAT COMFORT PACKAGE FRONT.

The Heat Comfort package front¹ provides the driver and front passenger with cosy warmth for the arms and hands as well, increasing comfort, particularly during cold times of the year. Along with seat heating for the front seats, the Heat Comfort package also includes heated armrests on the doors and front centre console, as well as steering-wheel heating.

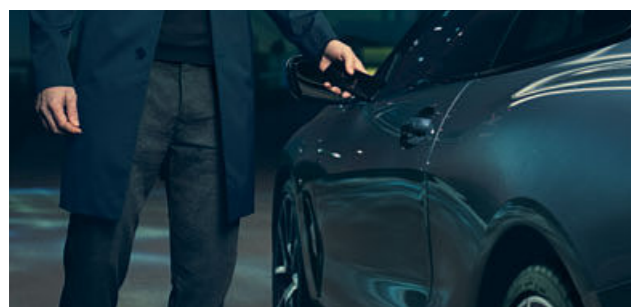

OPEN TO NEW EXPERIENCES: THE DIGITAL KEY.

Why take your key with you if you have your Android smartphone with you? The Digital Key^{1,2,*} or Key Card allows you to lock and unlock your BMW and even start the engine without needing a physical key. It can be downloaded to your Android smartphone using the BMW Connected app and shared with family and friends.

¹ Available as optional equipment.

² Prerequisite is a BMW ConnectedDrive account and a compatible smartphone with Android operating system, NFC technology and integrated secure element. Only compatible with selected Android smartphones with Android 8.0 or higher. For customers with non-compatible smartphones, a high-quality key card is provided.

³ Standard for BMW M850i xDrive.

* The availability of some equipment features and functions depends on engine variants or additional options. The market and production availability may vary. You can find detailed information about terms, standard and optional equipment at www.bmw.com or from your BMW Partner.

Some ConnectedDrive Services may differ between countries. Please consult your local BMW partner for more information.



ATMOSPHERE UP TO THE FINEST NUANCES: THE AMBIENT LIGHT.

The ambient light produces, through numerous LED lights, a pleasant lighting mood in the interior and a special sense of space in the dark. Colours, brightness and colour scenarios can be adjusted individually. The equipment includes contour and map pocket lighting as well as light guides in the centre console.



SMOOTHED SOUND FOR PURE SOUND ENJOYMENT: THE BOWERS & WILKINS DIAMOND SURROUND SOUND SYSTEM.

Seven aluminium aramid-fibre midrange speakers. Four aluminium tweeters. Three diamond tweeters. Two subwoofers with Rohacell core. In addition a 10-channel amplifier and a microphone-supported dynamic driving sound regulation, which supplies excellent sound through discreet control of the loudspeakers in each driving situation: The Bowers & Wilkins Diamond surround sound system¹ blends selected materials and high-end technology to create a unique, high-end audio experience.

TO FIND RELAXATION IS LUXURY: MULTIFUNCTION SEATS FOR DRIVER AND FRONT PASSENGER.

The Multifunction seats^{1,3,*} for driver and front passenger offer comprehensive adjustment possibilities and exceptional seating comfort and safety. This way, the seats can be optimally adapted to personal requirements by an electric backrest width adjustment, a variable lumbar support and a manual seat depth adjustment.



4

ONLY YOUR OWN WAY LEADS TO YOUR OWN GOALS.

Materials – hand crafted,
exquisite and exclusive.
Colours, surfaces and shapes
as individual as the
eyes that look upon it.
Ideas and expectations
are met without compromise –
and exceeded. Emotion is the
consequence of design:
Bayerische Motoren Werke.



BMW INDIVIDUAL.

THE EXPRESSION OF PERSONALITY.



The rich, bright colour of the BMW Individual paintwork in Brilliant White metallic is particularly special, which makes the captivating elegant presence of the BMW 8 Series Convertible even more intensely noticeable. This effect is caused by an elaborate 3-layer paint finish with a particularly high proportion of the Xirallic pigment.



Breathtaking Black: The complex, multi-stage production process begins with the application of several layers of dyed tulip wood. The special intensity of the surface is created during the finishing process by repeatedly applying and polishing deep black piano finish. The result is an incredible colour depth.

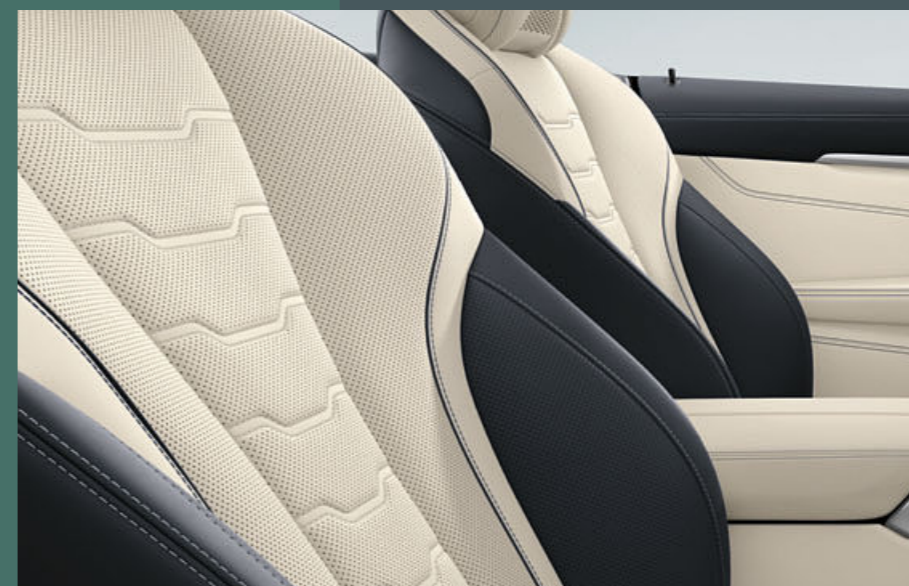

A breathtaking combination: The BMW Individual full leather trim 'Merino' interior in Bicolor Ivory White/Midnight blue with its fascinating colours and immaculate quality is a sign of individual, high-quality character. Details such as the leather door parapets in deep Midnight blue or the instrument panel with striking contrast stitching set special highlights here.

The special feature – as exclusive as you want it to be: The BMW 8 Series Convertible, inspired by BMW Individual, spurs the imagination at first glance. Choose from a wide range of high-quality, sophisticated interior and exterior equipment options. Or create exactly the BMW 8 Series Convertible you've always dreamed of. Because with BMW Individual everything is possible to express your personality. Discover a new, exclusive world: the world of BMW Individual.

WHICH COLOUR GIVES YOU DRIVING PLEASURE?

EXTERIOR COLOUR WORLD

Dravite Grey or Sunset Orange? Sonic Speed Blue or Barcelona Blue? The extroverted metallic colour palette for the BMW 8 Series Convertible will leave you spoiled for choice. For whichever paintwork you decide: You always choose ground-breaking design and uncompromising dynamics, which prove passion and character.

■ STANDARD EQUIPMENT □ OPTIONAL EQUIPMENT

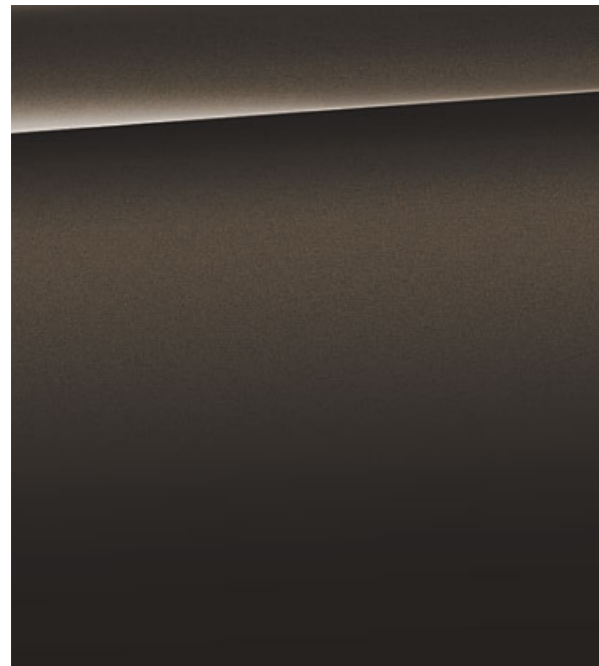

■ Non-metallic 300 Alpine White¹



□ Metallic A96 Mineral White²

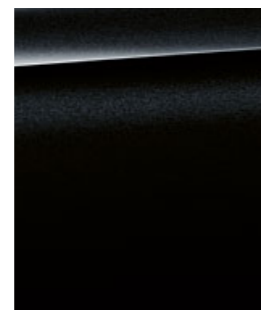

□ Metallic 475 Black Sapphire²

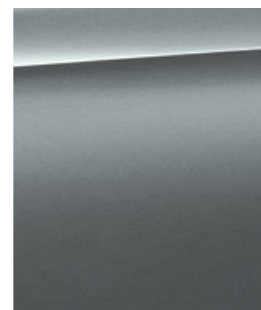

□ Metallic C2Y Bluestone²

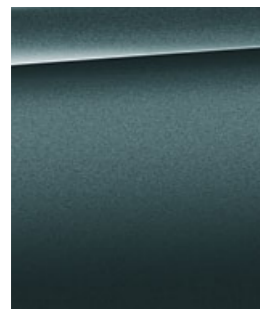

□ Metallic C35 Blue Ridge Mountain²



□ Metallic C1A Sonic Speed Blue²

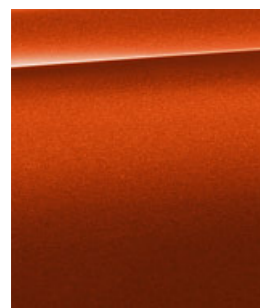
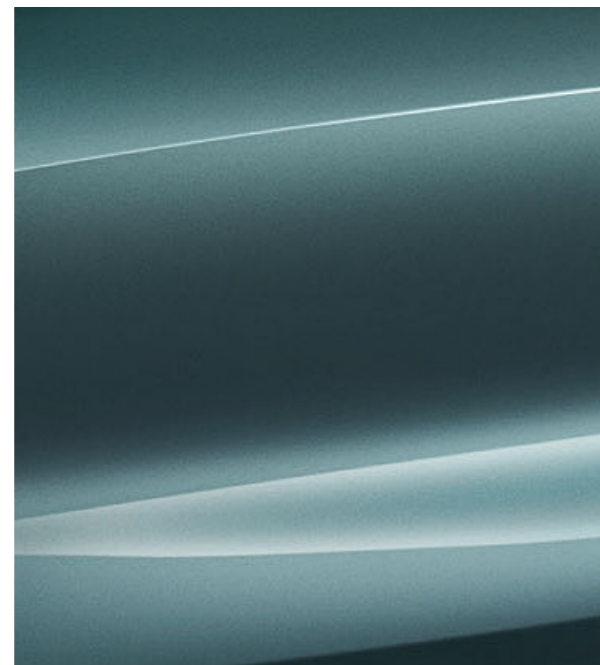

□ Metallic C1X Sunset Orange²



BMW INDIVIDUAL



□ BMW Individual C36 Dravit Grey metallic²



□ BMW Individual X1C Aventurine Red metallic²



□ BMW Individual special paintwork Frozen Arctic Grey metallic²



□ BMW Individual special paintwork Frozen Casmere Silver metallic²



□ BMW Individual X1D Frozen Bluestone metallic²

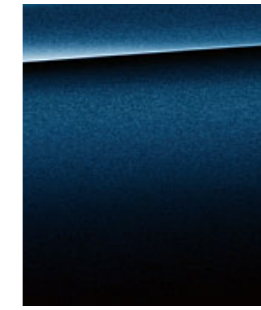

□ BMW Individual C3Z Tanzanite Blue metallic²



□ BMW Individual special paintwork Frozen Brilliant White metallic²



□ BMW Individual special paintwork Frozen Dark Silver metallic²



□ BMW Individual C46 Almandine Brown metallic²



□ BMW Individual special paintwork Brilliant White metallic²



□ BMW Individual special paintwork Pure metal Silver²



□ BMW Individual special paintwork Frozen Dark Brown metallic²

M SPORT PACKAGE

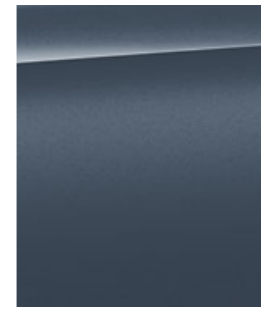

□ Metallic C38 Barcelona Blue²

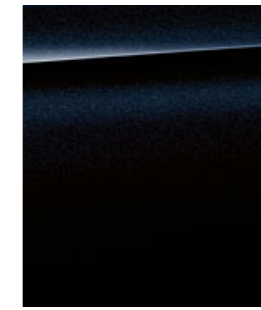

□ Metallic 416 Carbon Black²

[Colour samples] These colour samples are intended as an initial guide to the colours and materials available for your BMW. However, experience has shown that printed versions of paint, upholstery and interior trim colours cannot in all cases faithfully reproduce the appearance of the original colour. Please discuss your preferred colour choices with your BMW partner or dealership. There you can also see original samples and be assisted with special requests.

¹ Available as standard with the M Sport package and M850i xDrive.

² Optionally also available with the M Sport package and M850i xDrive.

³ Not available for M850i xDrive or in conjunction with M Sport package or BMW Individual Composition with M Sport features.

The Standard and Optional equipment may differ between countries. Please consult your local BMW partner for more information.



SPORTY IN WHITE. CLASSIC IN COPPER.

ELEGANT ACROSS THE BOARD



BRINGS HIGH GLOSS INTO THE STYLISH INTERIOR:
THE INTERIOR TRIM FINISHERS IN FINE-WOOD TRIM,
'FINELINE' COPPER EFFECT HIGH-GLOSS.

Get in and experience elegance across the board: Take a seat on the Multifunction seats* in the BMW Individual extended leather trim 'Merino' in Ivory White.^{1,2,*} In the stylish interplay with the interior trim finishers in Fine-wood trim, 'Fineline' copper effect² high-gloss, they are a real highlight for luxury-indulgent eyes that recognise what is special in every detail.

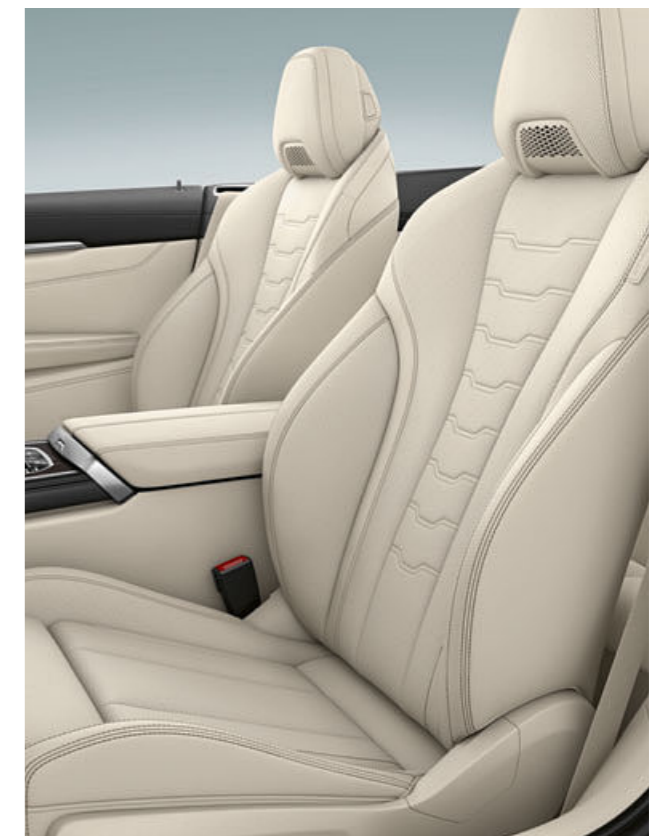

STRIKING AND STYLISH AT THE SAME TIME: THE BMW INDIVIDUAL
EXTENDED LEATHER TRIM 'MERINO' IN IVORY WHITE GIVES THE
INTERIOR A PARTICULARLY SPACIOUS AND ELEGANT ATMOSPHERE.



¹ Standard for M850i xDrive.
² Available as optional equipment.
*The availability of some equipment features and functions depends on engine variants or additional options. The market and production availability may vary. You can find detailed information about terms, standard and optional equipment at www.bmw.com or from your BMW Partner.

REAL HIGH-FLYER.

LUXURY BEYOND THE COMFORT ZONE



CLASSIC DETAILS THAT INDULGE THE EYES: THE FINELY GRAINED INTERIOR TRIM FINISHERS IN FINE-WOOD TRIM 'FINELINE' COPPER EFFECT HIGH-GLOSS.

Enjoy the unique combination of high performance and luxury: The Multifunction seats* in the BMW Individual extended leather trim 'Merino' in Cognac^{1,2} * make an impression not only with the cleverly designed perforation and decorative stitching in contrasting colours, but also with comfortable ergonomic seating with numerous adjustment options. The interior trim finishers in Fine-wood trim 'Fineline' copper effect high-gloss² additionally set exclusive accents.

LUXURY FOR THE EYES: THE BMW INDIVIDUAL EXTENDED LEATHER TRIM 'MERINO' IN COGNAC CAPTIVATES WITH IMPECCABLE, HIGH-CLASS QUALITY AND ALSO WITH ITS CHARACTERFUL COLOURING.

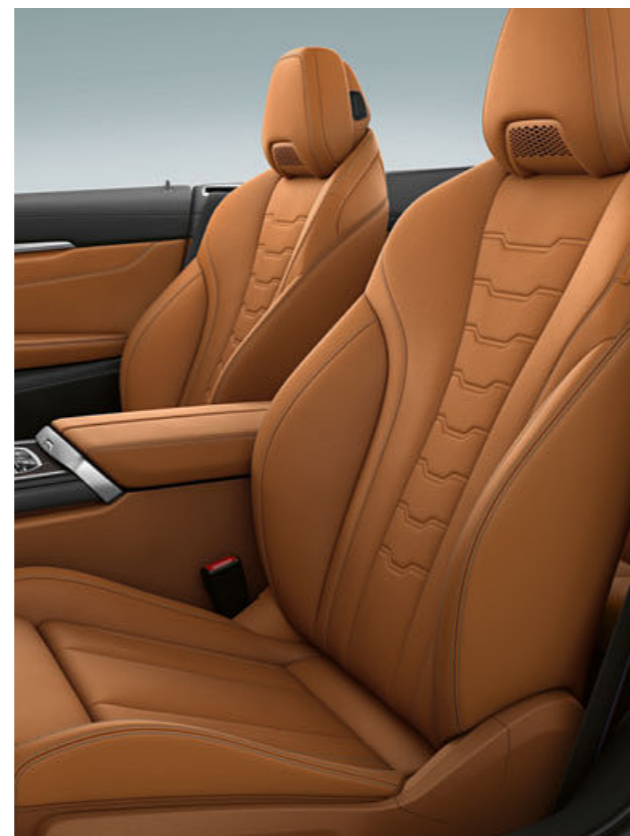

¹ Standard for M850i xDrive.
² Available as optional equipment.
 * The availability of some equipment features and functions depends on engine variants or additional options. The market and production availability may vary. You can find detailed information about terms, standard and optional equipment at www.bmw.com or from your BMW Partner.

PASSION IN RED, BLACK & STAINLESS STEEL.

TWO COLOURS. A LASTING IMPRESSION

As unexpected as expected: Elegant sportiness meets passionate red. The BMW Individual extended leather trim 'Merino' in Bicolor Fiona Red/Black^{2,*}, together with the interior trim finishers made of stainless steel fabric^{1,2,*}, sets a spirited statement that impressively underscores the outstanding dynamics.



THE INTERIOR TRIM FINISHERS IN STRIKINGLY SPORTY STAINLESS STEEL FABRIC OFFER A STYLISH TECHNICAL CONTRAST TO THE INTENSE COLOURS OF THE SEATS.

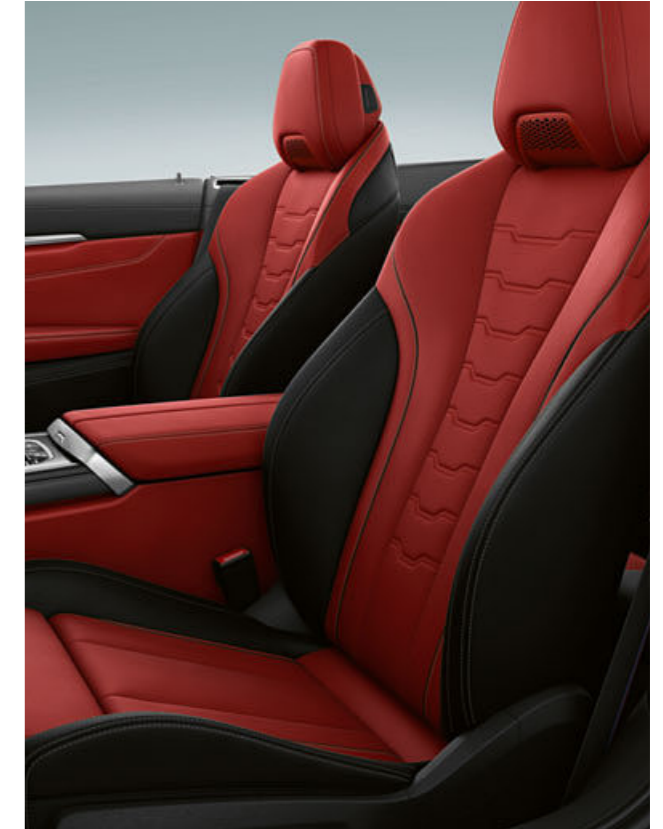

STRONG CONTRAST, STRONG EFFECT: THE MULTIFUNCTION SEATS* WITH PERFORATION AND COLOUR CONTRAST STITCHING, SHOWN HERE IN THE BMW INDIVIDUAL EXTENDED LEATHER TRIM 'MERINO' IN BICOLOR FIONA RED/BLACK, ARE^{1,2,*} VISUALLY, HAPTICALLY AND FUNCTIONALLY THE CENTREPIECE OF THE DYNAMIC INTERIOR.



TECHNICAL DATA.

	840i	840i xDrive	M850i xDrive	840d xDrive	
Weight					
Unladen weight EU ¹	kg	1905	1955	2090	2030
Maximum permissible weight	kg	2340	2400	2515	2485
Permitted load	kg	510	520	500	530
Luggage capacity	l	280–350	280–350	280–350	280–350
BMW TwinPower Turbo engine²					
Cylinders/valves		6/4	6/4	8/4	6/4
Capacity	cm ³	2998	2998	4395	2993
Max. output/engine speed	kW (hp)/rpm	250 (340)/5000–6500	250 (340)/5000–6500	390 (530)/5500–6000	235 (320)/4400
Max. torque/engine speed	Nm/rpm	500/1600–4500	500/1600–4500	750/1800–4600	680/1750–2250
Power transmission					
Type of drive		Rear wheel	All-wheel	All-wheel	All-wheel
Standard transmission		Steptronic Sport transmission	Steptronic Sport transmission	Steptronic Sport transmission	Steptronic Sport transmission
Performance					
Top speed	km/h	250 ²	250 ²	250 ²	250 ²
Acceleration 0–100 km/h	s	5.3	4.9	3.9	5.2
Consumption^{3,4} – All engines conform to the EU6 standard					
Urban	l/100 km	8.8–9.3	9.5–9.8	13.9–14.1	7.3–7.4
Extra-Urban	l/100 km	6.2–6.4	6.3–6.7	7.7–7.9	5.1–5.6
Combined	l/100 km	7.2–7.5	7.5–7.8	10.0–10.2	5.9–6.3
Exhaust emissions standard (type-certified)		EU6d-temp	EU6d-temp	EU6d-temp	EU6d-temp
Combined CO ₂ emissions	g/km	163–170	170–178	228–231	155–165
Tank capacity, approx.	l	68	68	68	66
Wheels/tyres					
Tyre dimensions		245/45 R18 Y 275/40 R18 Y	245/45 R18 Y 275/40 R18 Y	245/35 R20 Y 275/30 R20 Y	245/45 R18 Y 275/40 R18 Y
Wheel size		8 J x 18 9 J x 18	8 J x 18 9 J x 18	8 J x 20 9 J x 20	8 J x 18 9 J x 18
Material		Light alloy	Light alloy	Light alloy	Light alloy

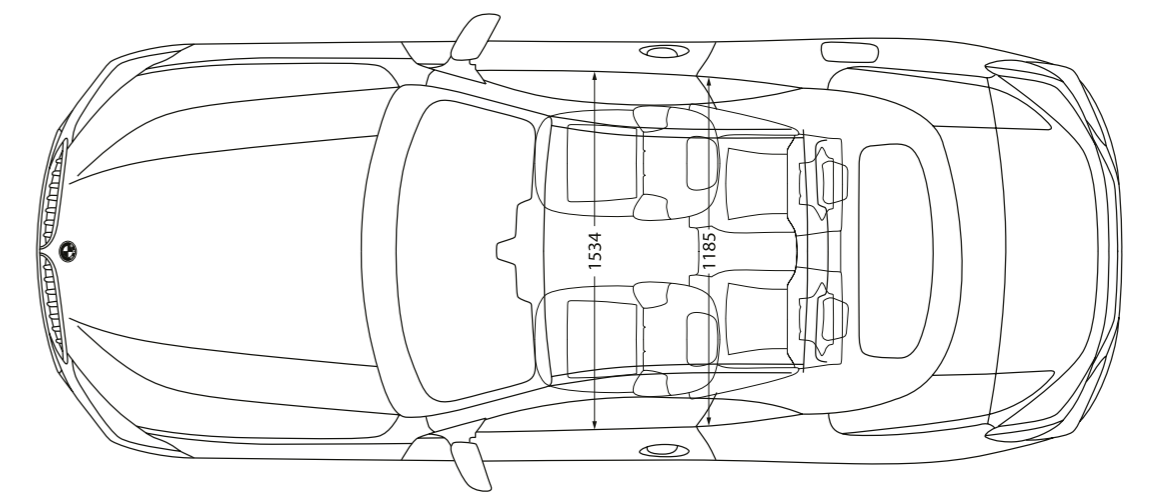
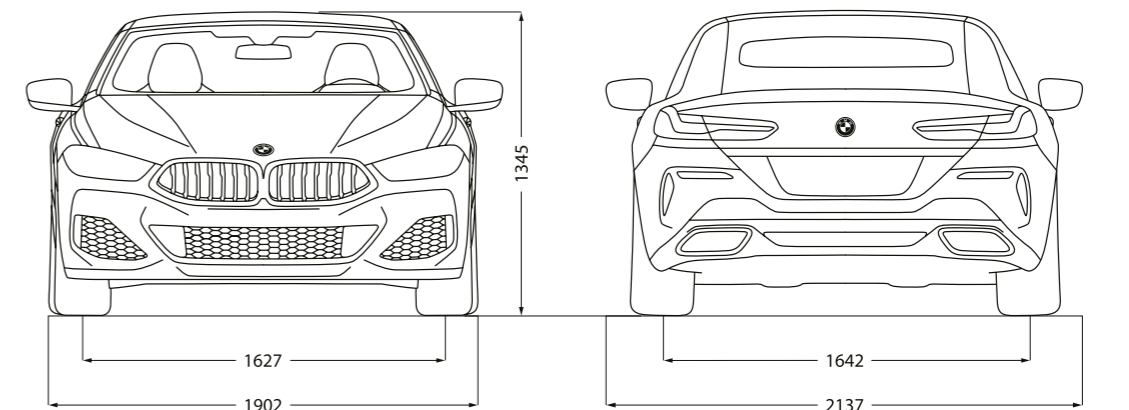
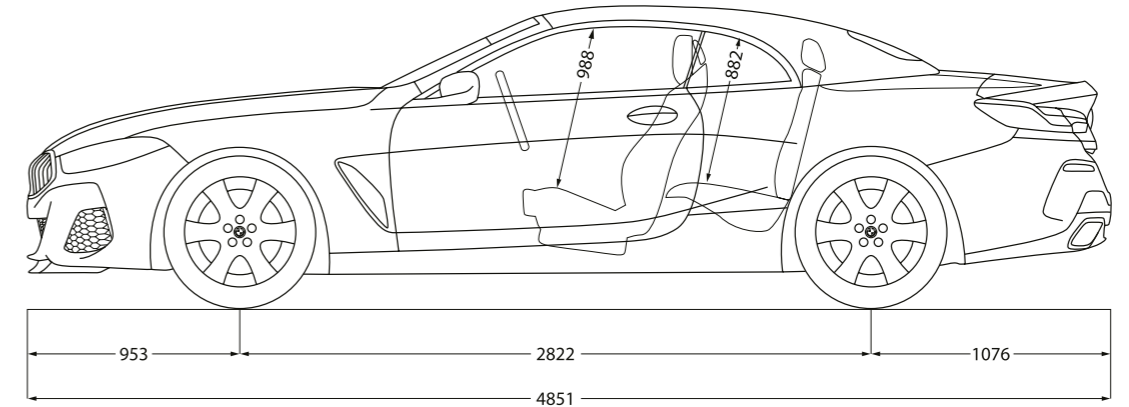

The dimensions specified apply for the BMW M850i xDrive Convertible.

¹ The EC unladen weight refers to a vehicle with standard equipment and does not include any optional extras. The unladen weight includes a 90% full tank and a driver weight of 75 kg. Optional equipment may affect the weight of the vehicle, the payload and the top speed if the selected equipment has an impact on the vehicle's aerodynamics.

² Electronically limited.

³ Performance data of petrol engines apply to vehicles using RON 98 fuel. Fuel consumption data apply to vehicles using reference fuels in accordance with EU Regulation 2007/715. Unleaded RON 91 and higher with a maximum ethanol content of 10% (E10) may also be used. BMW recommends RON 95 super unleaded petrol.

⁴ The data for fuel consumption, CO₂ emissions and energy consumption are determined in accordance with the measurements processes as defined by European Regulation (EU) 2007/715 in the applicable version. Data refer to a vehicle with base-level equipment in Germany, and the ranges account for differences according to the selected wheel and tyre size and the optional equipment and may change during the configuration process. Figures have been determined on the basis of the new WLTP test cycle and have been converted back into NEDC figures for comparability.



The models illustrated in this medium show the equipment and configuration options (standard and optional) for vehicles produced by BMW AG for the German market. Alterations in standard and optional equipment and the configurations available for the different models may occur after 11/12/2019, the editorial deadline for this medium, or according to the specific requirements of other markets. Your local BMW Partner is available to provide further details. Subject to change in design and equipment.

Of course, each vehicle is designed for economical recycling after its long-running life. You can find more information regarding your end-of-life vehicle on our website www.bmw.de/recycling.

© BMW AG, Munich, Germany. Not to be reproduced wholly or in part without prior written permission of BMW AG, Munich.
4 11 008 024 20 1 2020 CB. Printed in Germany 2020

BMW M850i xDrive:

BMW TwinPower Turbo 8-cylinder petrol engine, 390 kW (530 hp), 20" M light alloy wheels Y-spoke style 728 M Bicolour with mixed tyres, exterior colour in Dravite Grey metallic, softtop Black-Silver, seats in BMW Individual extended leather trim, Merino Ivory White, interior trim finishers in Fine-wood trim, Finesline copper effect high-gloss.

BMW M850i xDrive:

BMW TwinPower Turbo 8-cylinder petrol engine, 390 kW (530 hp), 20" M light alloy wheels Multi-spoke style 729 M Bicolour with mixed tyres and run-flat properties, exterior colour in Mineral White metallic, softtop Black-Silver, seats in BMW Individual extended leather trim, Merino Cognac, interior trim finishers in Fine-wood trim, Finesline Stripe copper effect high-gloss.

