



# A5 S5 Coupé | Cabriolet

Audi A5 Coupé | Cabriolet

 Audi S5 Coupé | Cabriolet

Vorsprung durch Technik **Audi** 



		Page		
<b>Fascination</b>				
	4	Audi A5 Coupé	32	Audi A5 Cabriolet
	20	Audi S5 Coupé	44	Audi S5 Cabriolet
<b>Technology</b>				
	56	Audi ultra	64	quattro®
	58	TFSI®	66	Audi drive select
	59	S engine	68	MMI® – Multi Media Interface
	60	TDI®	70	Audi connect
	62	S tronic®	72	Assistance systems
<b>Equipment</b>				
	76	Audi exclusive	102	Inlays
	78	Audi exclusive line	104	Lights and mirrors
	80	S line	105	Exterior equipment
	84	Style guides	107	Interior equipment
	88	Paint finishes	110	Infotainment
	90	Wheels/tyres	113	Assistance systems
	93	Hood colours, hood linings	114	Technology
	94	Seats/seat upholstery	115	Audi Extended Warranty
	101	Headlinings		
<b>Miscellaneous</b>				
	116	Audi Genuine Accessories	130	Index
	120	Technical data	138	The fascination of Audi
	128	Dimensions		

**Dialogue: Audi QR codes**

Experience Audi even more directly: download a QR app to your smart-phone and scan the QR code or use the given link provided in your browser.



The equipment for the vehicles illustrated in the Fascination section can be found on page 137. The fuel consumption and CO<sub>2</sub> emission figures can be found from page 120 onwards.





## The first coupé shaped by determination.

There is nothing more exciting than a premiere. Especially in your new car. The first sight of it. The first time you accelerate, the first corner, the first long ride. For this special feeling, there is a very special car: the Audi A5 Coupé. In an elegant design, with even greater driving dynamics. For new ways, new thoughts, new ideas. Get in. And experience every ride like it was the first.

The fuel consumption and CO<sub>2</sub> emission figures can be found from page 120 onwards.

# A5

Audi A5 Coupé

The Audi A5 Coupé plays with the proportions of classic coupés. The flat roof and the sweep of the roof line convey a sporty elegance. A multitude of rich colours and attractive tyre/wheel combinations between 17 and 20 inches in size emphasises the design.

The fuel consumption and CO<sub>2</sub> emission figures can be found from page 120 onwards.







The precise downward sloping lines of the expressive front and the three-dimensionally carved out bonnet symbolise determination and give the A5 Coupé a convincing stance. The sculptural transverse braces of the Singleframe are impressive and underline the three-dimensional design. The optional xenon plus headlights also have a striking LED daytime running light strip. The front fog lights are integrated into the high-gloss blade. The rear lights elegantly combine the side with the rear; the shoulder line passes through them and ends in a clear bumper edge.

The fuel consumption and CO<sub>2</sub> emission figures can be found from page 120 onwards.



The A5 Coupé not only looks sporty – the dynamism of its inner values are also very convincing. The quattro permanent all-wheel drive with wheel-selective torque distribution and self-locking centre differential will help you stay on track better. On request, quattro is also available with sport differential.

The A5 Coupé is extremely efficient: the highly supercharged injection engines are among the most economic and cleanest currently available worldwide. All engines are equipped as standard with start-stop system and recuperation.

The standard electromechanical power steering works depending on the speed and ensures greater steering precision and comfort. In addition, it only requires fuel if you actively request steering support.

The fuel consumption and CO<sub>2</sub> emission figures can be found from page 120 onwards.









Numerous innovative and advanced assistance systems increase both safety and comfort. For example, Audi active lane assist warns you if you inadvertently drift out of your lane, while adaptive cruise control regulates the distance to the vehicle in front – even bringing you to a complete standstill under certain circumstances. Audi drive select lets you drive according to your mood – comfortably or sportily as you prefer. On request, the dynamic steering option can be ordered with the system; this adapts to the selected mode and ensures smoother running or faster implementation of your steering commands.









The interior radiates elegance and sportiness. The architecture is harmonious and creates a lively atmosphere. Selected materials emphasise the high quality of workmanship, which you will see and above all feel. The standard leather-covered sport steering wheel in 3-spoke design provides good grip, as does the ergonomically shaped gear or selector lever knob, which is also leather-covered.

Operated via the MMI button with integrated joystick, the optional MMI navigation plus includes features such as a high-quality 7-inch colour display, 3D map representation and a hard drive for your personal music and media files.

On request, Audi connect with car phone gives you access to numerous services supported by Audi connect. These include, for example, the vehicle's own Wi-Fi hotspot, navigation with the aid of Google Earth™ mapping service\* and Google Street View™\* or online traffic information. More information about these features can be found on page 70 under Audi connect.

\* Google and the Google logo are registered trademarks of Google Inc.

No matter what you plan to do in your Audi A5 Coupé – you will enjoy every second. For example, the comfortable seats covered with whatever material you wish: exclusive cloth trim, finest-grade leather or a combination of high-quality Alcantara and leather. On request, you can also choose the ventilated and heated climate-controlled comfort seats in the front. The generous proportions of the optional electric panoramic tilt sunroof with sunblind make the journey even more pleasant for all the occupants.

The fuel consumption and CO<sub>2</sub> emission figures can be found from page 120 onwards.







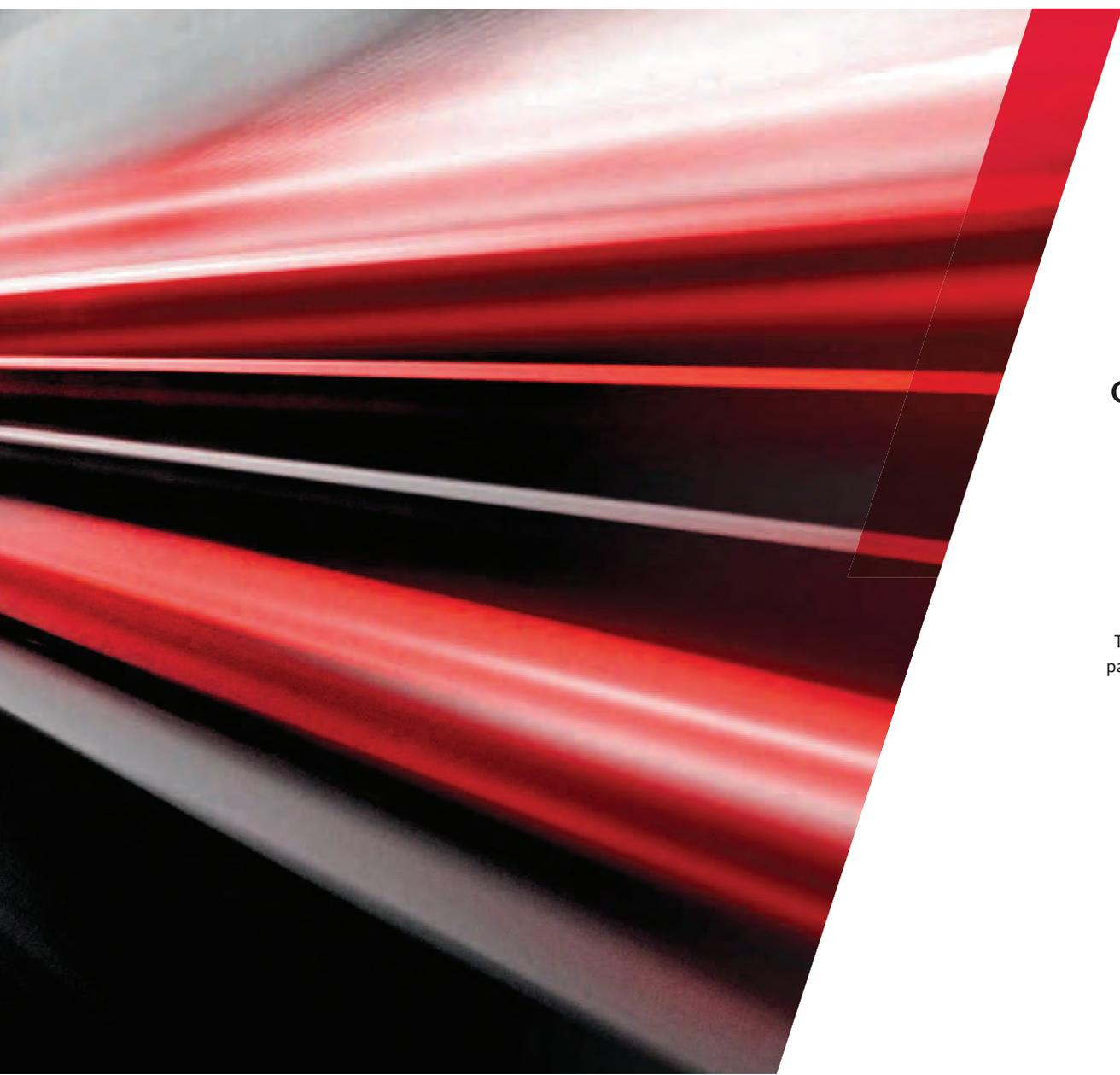

## A new form of sportiness.

A car in which the idea of “sport” has been embodied in a classic form – the Audi S5 Coupé. It is more than metal and engineering. It is dynamism that is now within reach. A sports car whose lines appear honed and polished. The agile engine concept challenges every road. Even more precise. Even sharper. Even more powerful. Admire it. And then: step inside.

The fuel consumption and CO<sub>2</sub> emission figures can be found on page 123.

# S5

Audi S5 Coupé

The Audi S5 Coupé positively sticks to the road: it is stronger stabilisers and stiffer spring/damper tuning that make this possible. Outstanding directional stability is provided by the broad track and long wheelbase.

A brief touch on the accelerator pedal is all that's needed: six supercharged cylinders respond immediately and release 245 kW of power. The TFSI technology ensures you move forward not only more quickly, but also more efficiently. The displacement of less than 3 litres makes the power unit light and sporty and generates 440 Nm, allowing you to accelerate to up to 250 km/h (regulated). In brief: more power for your engine – more pleasure on the road.

The fuel consumption and CO<sub>2</sub> emission figures can be found on page 123.







In the Audi S5 Coupé, the quattro permanent all-wheel drive works with wheel-selective torque distribution and self-locking centre differential. The system adapts to the changes in road surface in fractions of a second, thus providing outstanding traction. On request, quattro with sport differential guarantees even more acceleration performance, particularly round corners.

The electromechanical power steering system reacts quickly to your steering commands. The high-performance 17-inch brake system in the Audi S5 Coupé is exactly tuned to the sporty driving style of this car.

The fuel consumption and CO<sub>2</sub> emission figures can be found on page 123.



It only takes a moment for the Audi S5 Coupé to win you over. The drawn-out lines of the side sections appear to down, while with its flat roof the Audi S5 Coupé appears to be about to spring forward. The optional 19-inch cast aluminium wheels in 5-parallel-spoke star design reinforce the athletic impression. One blink of the eye and the Audi S5 Coupé is up and away.

The fuel consumption and CO<sub>2</sub> emission figures can be found on page 123.







The Audi Singleframe with the S5 logo catches the light, the bumper directs your view downwards to the front fog lights with surrounds in aluminium look. The S5 logo on the front brake callipers shimmers through the wheel spokes. The xenon plus headlights are equipped with an LED daytime running light strip. And the distinctive rear is not an end point, but a statement: the four oval twin tailpipes signal power, the clearly defined trailing edge suggests consistency.



The fuel consumption and CO<sub>2</sub> emission figures can be found on page 123.



The interior of the Audi S5 Coupé is characterised by pure sportiness: thanks to the optional S sport seats at the front with S5 embossing, seat heating, front, and electrical seat adjustment as well as the leather-covered multifunction sport steering wheel with S5 emblem and shift paddles in aluminium look. The interior is generously comfortable. The headlining in black or optionally in lunar silver creates a dynamic tension. High-quality inlays in matt brushed aluminium, piano finish, black, carbon Atlas, stainless steel mesh, fine grain birch, grey or aluminium/Beaufort, black set fascinating highlights. The ergonomic layout of the instruments makes them very easy to operate. It feels as though you had never driven another car.

The fuel consumption and CO<sub>2</sub> emission figures can be found on page 123.







## More experience: a new driving sensation.

There are moments you have already experienced lots of times. But all of a sudden, they feel new again. Because all at once everything feels more intense. Because you feel more and experience more than usual.

A ride in the Audi A5 Cabriolet is one of those moments. Because you exchange what you are used to for something unusual. And you feel that it is more than just a Cabriolet. It is a new driving sensation.

The fuel consumption and CO<sub>2</sub> emission figures can be found from page 124 onwards.

# A5

Audi A5 Cabriolet





The first exciting journey is made by your eyes. The moment they take in the silhouette of the Audi A5 Cabriolet. Its long wheelbase. The extended bonnet. The short overhangs. Details which underline the athletic Coupé character just as much as the striking body lines do.

An unmistakable presence with the fully automatic fabric hood: it is characterised by a high degree of comfort and well thought out details when both open and closed. So it only takes 15 seconds for it to let the summer in. Up to a speed of 50 km/h the hood can be operated while driving. Only the optional acoustic hood is even more impressive. When closed, it reduces noise so effectively that you can fully concentrate on your driving experience.

The fuel consumption and CO<sub>2</sub> emission figures can be found from page 124 onwards.

With the extremely efficient TFSI and TDI engines in the Audi A5 Cabriolet you will soon forget your everyday affairs and get on with discovering something new. Enormous torque strength and power reserves characterise the engines just as smooth running and efficiency. Bundled engineering power is embedded in each of the engines.

When cornering, you feel the athletic character particularly clearly. One of the factors responsible for this is the optional quattro all-wheel drive with wheel-selective torque distribution and self-locking centre differential which variably distributes driving force. The electromechanical power steering assists you with high dynamics in curves and stability on the straight.

The fuel consumption and CO<sub>2</sub> emission figures can be found from page 124 onwards.

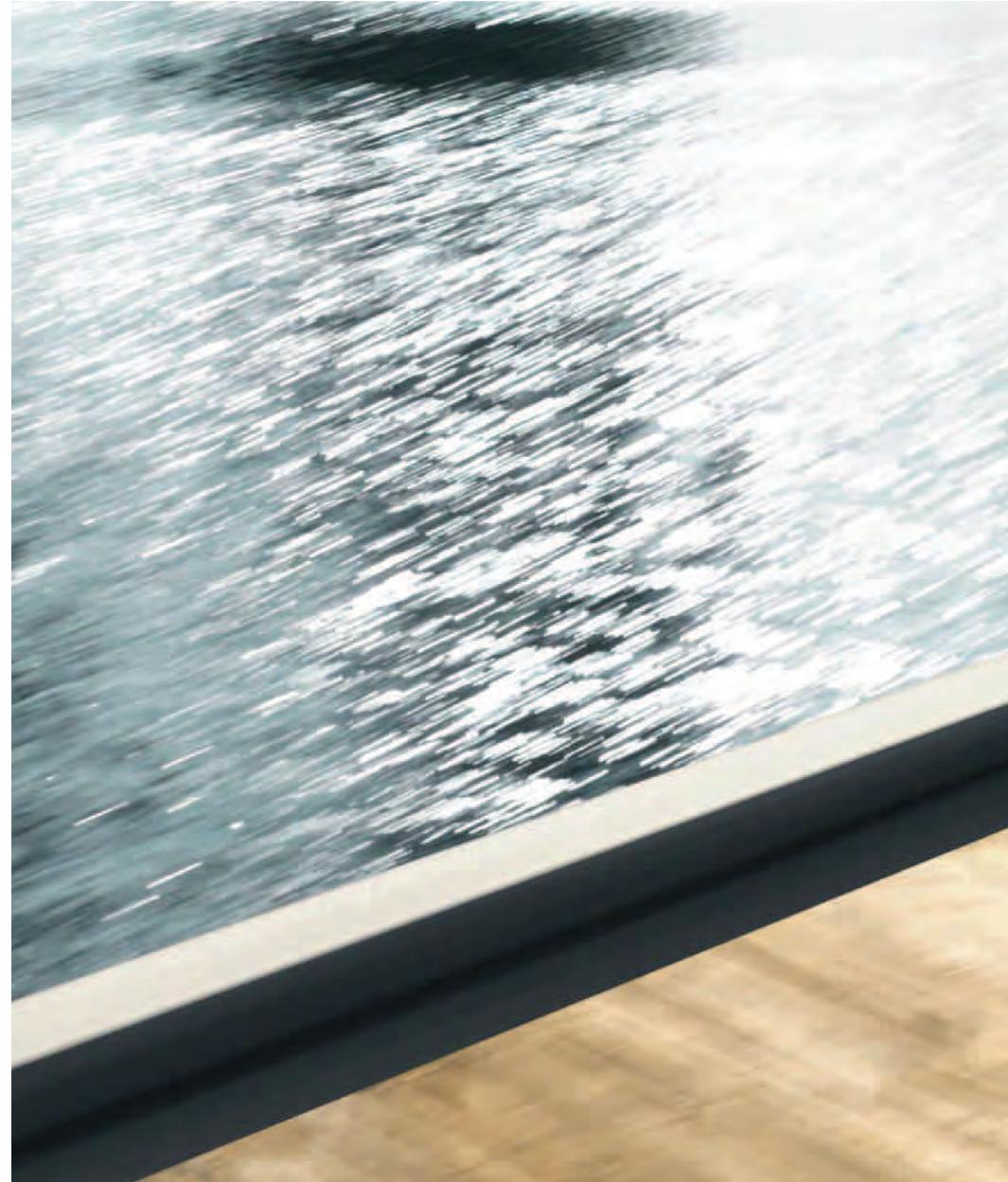







The optional xenon plus headlights with LED daytime running light strip give the Audi A5 Cabriolet a determined look. The striking front section and the layout of the horizontal lines on the rear enhance this impression. Exclusivity does not fall by the wayside: accentuated high-gloss elements highlight the individuality and turn each stop into sheer enjoyment.

The fuel consumption and CO<sub>2</sub> emission figures can be found from page 124 onwards.

It is the intense driving moments which make the Audi A5 Cabriolet so inviting, and these moments are expressed in the interior. At a glance you are aware of the tremendous attention to exclusivity, design and technology. And to your comfort: on request, heated and ventilated climate-controlled comfort seats as well as headroom heating at the front make for a relaxed journey. The automatic belt presenter and the optional cup holders integrated in the rear bench seat make the journey even more pleasant.

The fuel consumption and CO<sub>2</sub> emission figures can be found from page 124 onwards.







Top-quality materials create a sovereign atmosphere and emphasise the high-quality craftsmanship. Each detail is ergonomically tailored to the driver – like the optional MMI navigation plus, for example. You can navigate using the high-resolution colour display and the aid of 3D map representation – or even with Google Earth™ mapping service\* and Google Street View™ \* in conjunction with Audi connect with car phone. At the same time, you can use the integrated hard disk for your music and video files. Just in case you want to enjoy more than the wind in your hair and the countryside.

\* Google and the Google logo are registered trademarks of Google Inc.







# Can do more. If that's what you want.

What makes the Audi S5 Cabriolet stand out? The fact that it makes every summer an adventure, because it can be driven in an even more challenging way. A powerful engine and its absolutely athletic tuning make it almost as agile as a full-blooded sports car. That is why it can do more. That is why it is the S5 Cabriolet.

The fuel consumption and CO<sub>2</sub> emission figures can be found on page 126.

# S5

Audi S5 Cabriolet

Every day you get a choice with the S5 Cabriolet: How do you want to have fun? Is it a day to test the quattro permanent all-wheel drive? Or to provoke the high-performance brake system with ventilated brake discs? Or to exploit the 245 kW of the V6 TFSI engine and feel just how excellently the S sport suspension corresponds to your favourite stretch of road? If so, then increase the revs and get acquainted with the athletic genes of the S5 Cabriolet. Whatever type of fun you feel like having, you will get lots of it.

The fuel consumption and CO<sub>2</sub> emission figures can be found on page 126.









Not only can you have a marvellous time with the S5 Cabriolet, you can also effortlessly make up time. The natural dynamism of the S5 Cabriolet can be further adapted to your own personal driving style with the optional Audi drive select. The efficiency mode makes your journey particularly economical. At the same time, a range of different optional systems ensure your safety: Audi active lane assist warns you if you inadvertently drift out of your lane, while adaptive cruise control regulates the distance to the vehicle in front through automatic braking and acceleration – even bringing you to a complete standstill if necessary. And the electromechanical steering reacts with efficiency and at lightning speed to your steering commands.

The fuel consumption and CO<sub>2</sub> emission figures can be found on page 126.

A high degree of sportiness – during every ride. The drawn-out silhouette begins with the powerful front end: striking xenon plus headlights with LED daytime running light strip immediately draw attention to the bold character of the S5 Cabriolet. Oval twin tailpipes and LED rear lights catch the eye. A long wheelbase, short overhangs and the red S5 emblem in the Singleframe signal a readiness to perform. The standard acoustic hood completes the aerodynamic silhouette.

The fuel consumption and CO<sub>2</sub> emission figures can be found on page 126.

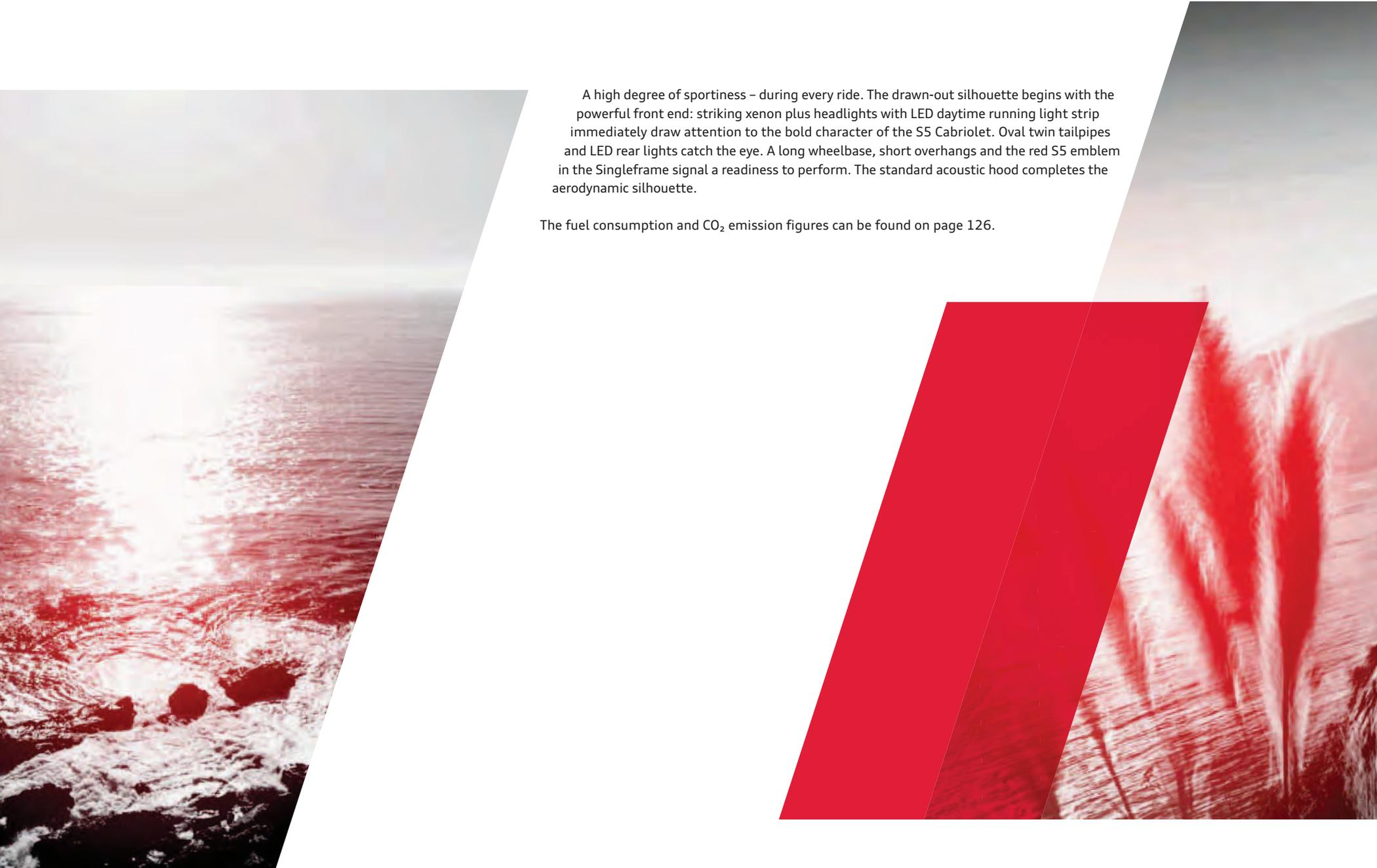









Share your driving adventure with others, even if there is a risk that your travel companions will never want to get out again: superb comfort and excellent manufacturing ensure that the occupants of the four full-size seats get maximum enjoyment from their cabriolet experience. The luggage compartment has a capacity of 320 l when the hood is open and 380 l when it is closed. A folding rear seat backrest and the through-load facility increase the luggage space still further to 750 l. Despite all this practicality, there is no shortage of fun to be had either, particularly if you decide on the optional MMI navigation plus. Together with the services supported by Audi connect and optional Audi connect including car phone, this puts communication and navigation functions such as Google Earth™ mapping service\* and Google Street View™\* or the point-of-interest (POI) search at your disposal. The Alcantara/leather combination, the leather-covered multifunction sport steering wheel in 3-spoke design with shift paddles in aluminium look and the special S design instrument cluster ensure that the vehicle's dynamism is reflected in the interior too. If ever being seated could be sporty, it would be so in the S5 Cabriolet.

\* Google and the Google logo are registered trademarks of Google Inc.

The fuel consumption and CO<sub>2</sub> emission figures can be found on page 126.

The image shows optional S sport seats, front.





Audi ultra on the podium: the Audi R18 TDI ultra

# Audi ultra:

## Every gram less extends the lead.

Audi ultra, the pioneering lightweight technology from Audi, is more than just the sum of its individual components. It combines innovative materials, intelligent design principles and production processes that use resources sparingly into an overall concept. Many Audi ultra lightweight measures have already been implemented in the Audi A5 and S5 models.

That starts with the body itself. The steel shell design of the Audi A5 und S5 models combines

low weight with high rigidity. The design uses just the right amount of material needed in just the right places to achieve the best result. Thin metal panels made of hot- and cold-formed steel in the body structure are combined with lightweight but sturdy aluminium in the body plating on the wings.

The aluminium components on the front and rear axle and the aluminium alloy wheels not only reduce the overall weight but also the unsprung

masses, which in turn leads to a further increase in agility and driving comfort.

Drive technologies such as direct fuel injection and turbocharging have made Audi engines more and more powerful. The modern TDI and TFSI engines in the A5 and S5 models produce more power with a smaller engine size, making them significantly lighter than the corresponding engines used in earlier model series.

Each lightweight component has an effect on other components, allowing their dimensions to be reduced as well. The result is a continuous development process towards less and less weight and more and more efficiency. In figures: a vehicle that weighs 100 kg less can save up to 0.3 litres of fuel per 100 km.

The fuel consumption and CO<sub>2</sub> emission figures can be found from page 120 onwards.

About weight reduction

**The demands placed on modern vehicles are contradictory.** On the one hand, they must offer enhanced performance and comfort, on the other they need to be more economical and efficient. Audi ultra resolves this conflict by examining each and every component. We demand the highest functionality combined with the lowest possible weight. The result is an intelligent mix of materials that even allows a reduction in engine size: lighter vehicles no longer need a large engine to be agile. Thus in 2012, for instance, both the Audi R18 e-tron quattro and the Audi R18 ultra drove to podium finishes at Le Mans with a V6 engine, whereas their victorious predecessor in 2010, the R15 TDI, had featured a V10 engine.



- Aluminium sheet
- Aluminium profile
- Hot-formed steel
- Cold-formed steel



**The engine management system** calculates the injection quantity and ignition timing according to how much power the driver wants. In normal operation the injection pressure is between 30 and 120 bar.

- fully electronic coolant regulation
- powertrain with reduced friction losses
- dual FSI/MPI injection system
- Audi valvelift system and double camshaft adjustment
- cylinder head with integrated exhaust-gas cooling



1.8 litre TFSI engine

Many hours of development time. Thousands of miles of testing. And for what reason?

## In just a few seconds you will understand why.

The Audi A5 Coupé and the A5 Cabriolet employ TFSI technology. And the remarkable thing about it is that it combines the advantages of FSI® with a turbocharger, which ensures even better power distribution. The TFSI engines you can choose from are all equipped with the economic start-stop system.

The 1.8 TFSI has 125 kW of power and a maximum torque of 320 Nm. It is one of the most fuel-

efficient engines of its class: in the ideal case, consumption is as low as 5.7 l per 100 km in the A5 Coupé with manual transmission. It accelerates from 0 to 100 km/h in 7.9 seconds. In the A5 Cabriolet it takes 8.7 seconds to reach the 100 km/h marker. The 2.0 TFSI has 165 kW of power and a maximum torque of 350 Nm. This engine version is also characterised by good consumption values and low CO<sub>2</sub> emissions, and gets you from 0 to 100 km/h in

6.4 seconds in the A5 Coupé with quattro drive and S tronic. Both engines already comply with the EU6 emission standard.

The fuel consumption and CO<sub>2</sub> emission figures can be found from page 120 onwards.



- switchable water pump
- integrated supercharger module
- high-pressure pump
- timing drive chain



3.0 litre V6 TFSI engine

S engine:

## More dynamics. More power. Completely S.

The Audi S5 Coupé and the Audi S5 Cabriolet also feature efficient TFSI technology. These two vehicles have a 3.0 litre V6 TFSI engine that generates a powerful 245 kW. An innovative mechanically driven supercharger system with intercooling is employed here and turns the six-cylinder engine into a compact powerhouse with moderate fuel consumption. This is assisted by the start-stop system that switches the engine

off automatically in different standstill situations, and switches it on again when the brake is released. The S5 Coupé and S5 Cabriolet are available with the fast, 7-speed dual-clutch transmission S tronic and quattro permanent all-wheel drive.

The peak torque of 440 Nm is sure to impress you, as will the torque curve: with at least 90%

of the maximum torque being available across an engine speed range of 2,900 to 5,300 rpm. Thanks to its spontaneous responsiveness and exceptional power delivery across the entire engine speed range, the 6-cylinder engine promotes a particularly dynamic driving style. That way, it accelerates the S5 Coupé from 0 to 100 km/h in 4.9 seconds and the S5 Cabriolet in 5.4 seconds.



**The piezo injectors** open and close in fractions of a millisecond and inject fuel several times into the combustion chamber at pressures of up to 2,000 bar. In some cases, an injection process can involve the injection of the tiniest of amounts weighing less than a thousandth of a gram.



**Pre-injection** results in a “gentle” combustion process and consequently excellent combustion acoustics and agreeable engine running characteristics.

# TDI®

## In other words: Where is the tank?

One in every two Audi cars sold today is a diesel. What sounds perfectly normal now was cause for huge excitement 20 years ago, when Audi revolutionised the market with the first 2.5 litre TDI engine. Since then, developments such as common rail technology have made TDI even more efficient. Piezo injectors ensure the fuel is finely and precisely distributed. Consequently, since the first TDI, the engines have become more economical, whilst specific output has increased. So it was only logical that a diesel car

should then enter the world of motorsport. And successfully too: in 2006, Audi was the first car maker to win the Le Mans 24 Hours with a diesel-powered race car, the Audi R10 TDI – and then went on to repeat this victory several times over.

Powerful TDI engines are available for the Audi A5 Coupé and A5 Cabriolet, and these are equipped with intelligent common rail technology and the start-stop system as standard. The particularly

economical 2.0 TDI with 130 kW is available both with a 6-speed manual transmission and with the convenient multitronic® system. In the Audi A5 Coupé, it can also be combined with quattro and the 7-speed dual-clutch transmission S tronic.

The 3.0 TDI with 150 kW is one of the most efficient 6-cylinder engines in the world. The top-of-the-range engine is the 3.0 TDI quattro with 180 kW and S tronic. To reach 100 km/h takes just 5.8 seconds with this engine in the A5 Coupé

and only half a second longer in the A5 Cabriolet. On request, this engine variant is also available in the A5 Coupé as a 3.0 TDI clean diesel with quattro and 7-speed dual-clutch transmission S tronic. This engine uses technology which specifically reduces nitrogen oxides. This engine version fulfils the EU6 emission standard.

The fuel consumption and CO<sub>2</sub> emission figures can be found from page 121 onwards.

- 2,000 bar high-pressure injection system
- turbocharger with optimised adjustable turbine geometry
- engine with reduced friction
- pressure-regulated oil pump
- innovative thermal management with separate cooling system for engine block/cylinder head



3.0 litre TDI engine (150 kW)

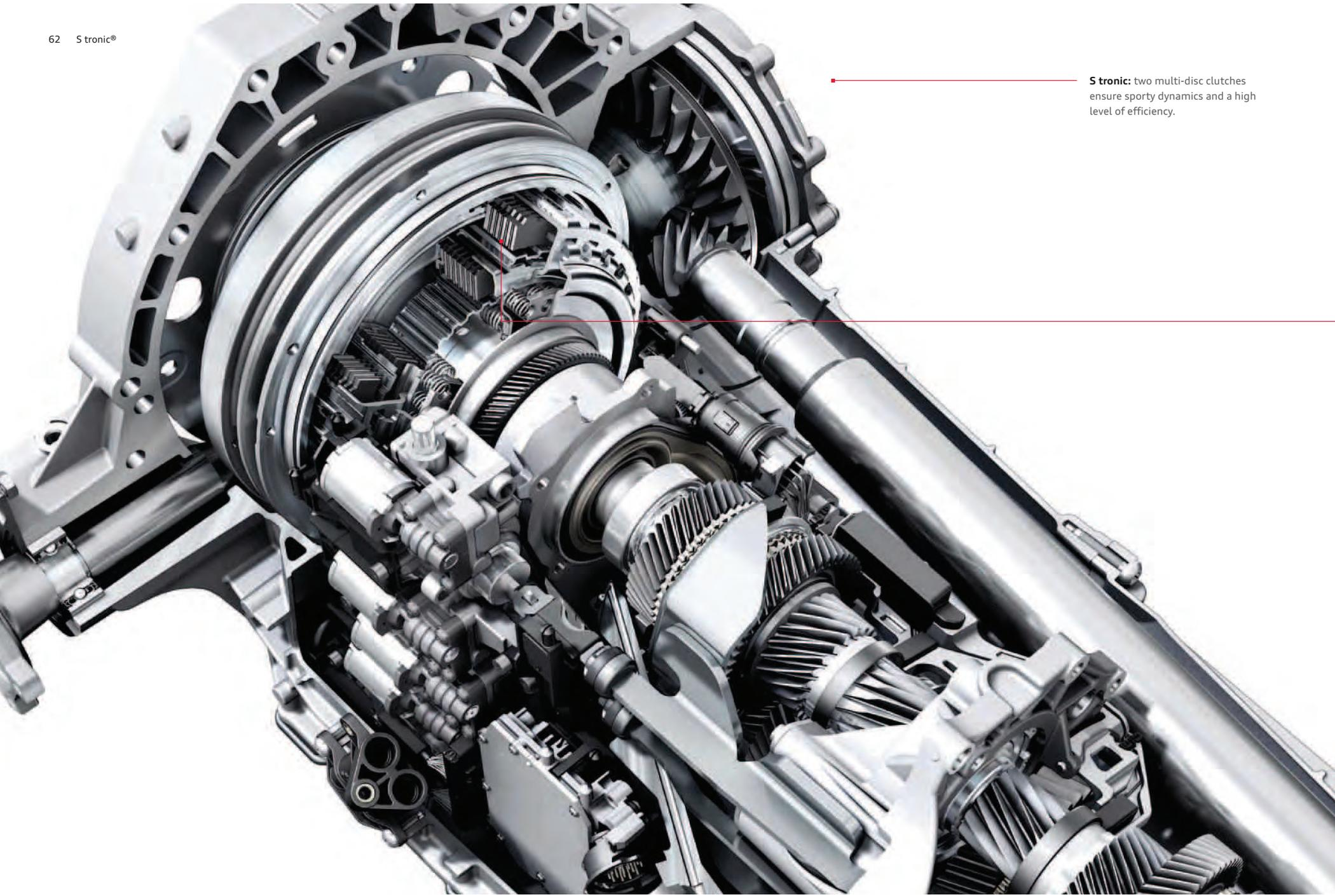

**S tronic:** two multi-disc clutches ensure sporty dynamics and a high level of efficiency.

# What is the benefit of two clutches?

---

A double saving: time and energy.

The 7-speed dual-clutch transmission enables rapid gear shifting with hardly any perceptible break in propulsive power and is therefore particularly efficient.

As long ago as 1985, Walter Röhrl tested this technology in the Sport quattro S1 – and was suitably impressed. Audi drivers share his enthusiasm to this day, because the modern S tronic changes gear in a flash. To do this, two multi-plate clutches serve the different gears. One large clutch transfers the torque via a solid drive shaft to the gearwheels of the gear wheels of the odd-numbered gears. A second clutch

serves the even-numbered gears via a hollow shaft. Both parts of the transmission are permanently active, although there is only ever one actively connected to the engine via a closed clutch. For example, if the vehicle is accelerating in third gear, then the second part of the transmission is already engaged in fourth gear. The gear change happens very quickly through the change of clutches – the first clutch opens, whilst the second one closes. The gear change only takes a few hundredths of a second and is completed with virtually no interruption in the power flow. It runs so smoothly and comfortably that the driver barely notices it.

It does not matter whether the driver chooses the fully automatic modes with the program D (Drive) or S (Sport) or changes gears manually with the shift paddles – the gear change feels precise and extremely sporty. Even with all of this dynamic technology, the S tronic still remains very efficient. Its high level of efficiency helps to reduce both fuel consumption and emissions.

The fuel consumption and CO<sub>2</sub> emission figures can be found from page 120 onwards.



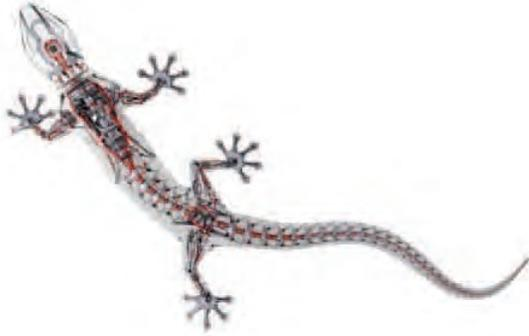

## Why only use two wheels when a car has four?

### The quattro® permanent all-wheel drive.

quattro is a permanent all-wheel drive system. If the wheels on one axle of the vehicle lose grip on the road and threaten to spin, then the drive force is transferred to the other axle – automatically and permanently distributed through the centre differential. The basic distribution is 40:60 – 40 % of the driving power comes from the front axle, 60 % from the rear. The benefit is better traction during acceleration and improved safety due to exceptional grip. So much for the technology. But what makes quattro unique is really the driving feel. “As if you are stuck to the road,” some customers say.

We put it like this: quattro gives you a better feel for the road and thus more safety.

The optional quattro with sport differential further reinforces this unmistakable quattro feeling. Vehicles tend to experience understeer when steering or driving into corners. This is a normal physical process: a moving object opposes a change in direction. The elastic tyres and the suspension mounts tense up until the new direction has been adopted. When accelerating into a corner, the load on the front axle is reduced and it therefore transfers less

lateral force to the tyres – the vehicle understeers. With the sport differential on the rear axle, the tendency to understeer is largely counteracted.

This is because the quattro rear axle differential has been extended left and right by a clutch system with two gear levels. They ensure that the individual wheels on the rear axle receive different levels of torque. The clutches are activated by an electro-hydraulic actuator. Depending, for example, on the steering angle, lateral acceleration, yaw angle and driving speed, the system calculates the right distribution of

wheel torque for any driving situation. In this way the power is specifically channelled to the outer rear wheel, when steering or accelerating into a corner. The effect: the vehicle is effectively pressed into the corner by the drive force and follows the angle of the front wheels. The variable left and right driving forces also help stabilise the steering and the usual steering corrections are hardly necessary.

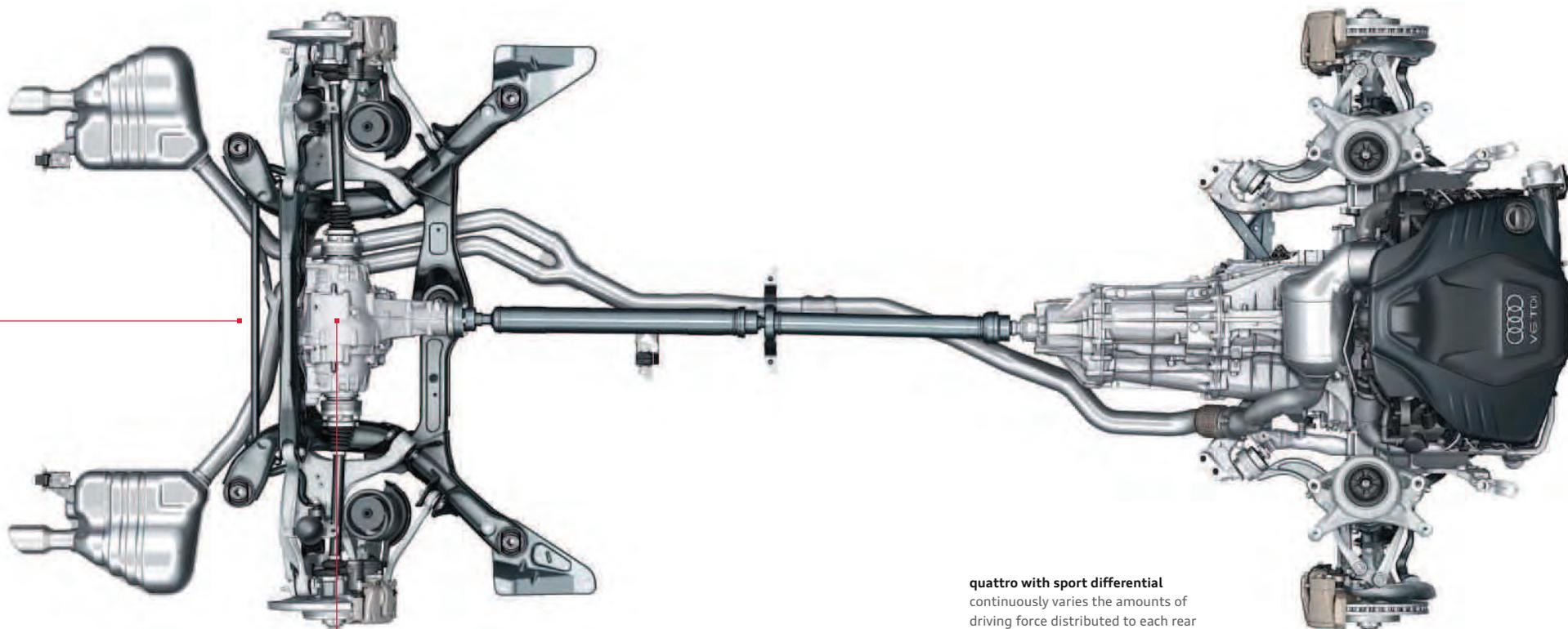

**quattro with sport differential**  
continuously varies the amounts of  
driving force distributed to each rear  
wheel and ensures high cornering  
agility and impressive driving  
dynamics.

Why do the Audi A5 and S5 suit you so well?  
Because they adapt themselves to you so well.

Audi drive select.



comfort



dynamic



auto



efficiency



individual

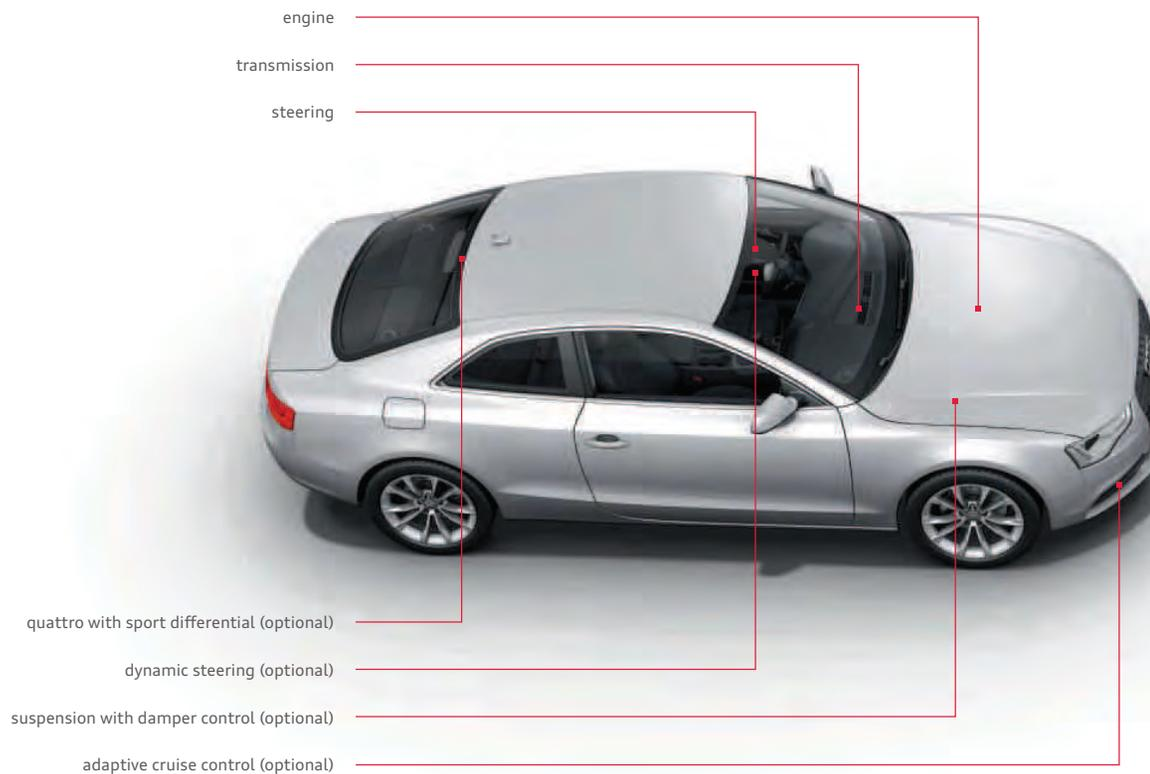

Everybody defines driving dynamics differently. We define it like this: drive exactly how you feel. With the optional Audi drive select, you can influence individual vehicle components at the push of a button and so change the character of your Audi.

You have up to five modes to choose from: efficiency, comfort, auto, dynamic and, in conjunction with one of the optional MMI navigation systems, individual mode, allowing you to determine yourself how the associated vehicle components should behave. The comfort mode is especially suitable for providing the most relaxed driving

possible on long journeys. The auto mode offers a generally comfortable yet sporty driving experience. For particularly sporty driving, for example on winding roads, there is the dynamic mode. The efficiency mode, however, allows consumption-improved driving. As an integral part of Audi drive select, it is characterised by energy-enhanced operation of the engine and secondary consumers such as the air conditioning, as well as by changing the shift program in models with automatic transmission.

In every mode, the vehicle adjustments depend on the equipment present. Audi drive select

affects the engine, automatic transmission and steering as standard. Other features you can also influence – if fitted – include the suspension with damper control, the dynamic steering and quattro with sport differential. The engine and gears react more spontaneously or in a more balanced manner to movements of the accelerator, depending on the mode chosen. Moreover, the engine speeds at which gear changes take place are varied in models with automatic transmission – in dynamic mode, they only happen at higher engine speeds, while in comfort mode they take place at lower ones. The steering can also be adapted to the driving

situation, from sporty and firm to comfortable, and in connection with the dynamic steering, between sporty-direct and comfortable-indirect as well. quattro with sport differential distributes the drive force variably to the rear axle to attain a high level of agility and acceleration performance while cornering.

adaptive cruise control can also be set to be either more balanced or more spontaneous in relation to acceleration behaviour and as a reaction to the vehicle in front.

# Follow your intuition.

---

## And you'll get there.

We try to match up to our claim of “Vorsprung durch Technik” in every aspect of an Audi – for example with the advanced optional MMI – Multi Media Interface. The MMI is used to control a wide variety of media in the vehicle, as well as the navigation system and other convenience functions. In addition, you can use it to control the optional services supported by Audi connect.

The 6.5-inch or 7-inch colour display presents all the information in a very attractive look and with impressive clarity.

It used to be simple to operate the MMI navigation plus – and now it's even simpler. A reduced number of buttons brings greater clarity. All six so-called hard keys, for the telephone, navigation or car set-up functions for example, are located around the central rotary/push-button control – for intuitive operation. The operating buttons for radio and media are logically arranged near the volume control. The carousel layout in the MMI display provides you with an even better overview, making it easier for you to get to where you want to be.



**Radio:** the integrated radio receiver is set up for VHF, LW and MW and optionally delivers digital radio with a continually updated station list.



**Media:** display of available media sources such as the jukebox, inserted SDHC cards, Audi music interface or CDs and DVDs; display of optional TV tuners



**Telephone/Bluetooth:** the optionally available preparation for mobile phone (Bluetooth) and Audi connect including car phone has a menu screen with call lists, address book and selection interface as the initial setting.



**Car:** this function allows the direct control of driver assistance systems, vehicle settings, climate control and service functions.



**Audi connect:** All services supported by Audi connect can be quickly and easily used via the MMI. Intuitive operation of the MMI makes accessing the Internet very easy.



# Audi connect:

## The intelligent connection between the internet, the vehicle and you.

---

These days, we are connected everywhere and at all times – at home, at work and on the move. Being connected whenever you wish, even in your car, is what modern mobility is all about. Audi connect keeps you connected to the world via the data module integrated in the vehicle. You can access the contacts and music collection on your mobile phone<sup>1</sup> conveniently and directly via Bluetooth. In addition, there is a Wi-Fi hotspot for wireless connection of up to eight mobile devices. You can use Audi connect to find out more about cultural events in town, find the cheapest petrol stations nearby, put your own

personal route together at home and then transfer it to the navigation system, or explore your destination online in advance. The numerous integrated services and functions allow the vehicle to become part of the global network – increasing comfort and taking automotive fun to new heights. Simple, fast and customised.

Further detailed notes on availability and legal information about Audi connect, the technical requirements (necessary optional equipment, mobile phone contract, registration), any costs which may be incurred and the respective

conditions of use can be found on page 112 of this catalogue. Please contact your Audi partner for information about the availability and scope of the services supported by Audi connect or visit [www.audi.com/connect](http://www.audi.com/connect).

<sup>1</sup> Please visit [www.audi.com/bluetooth](http://www.audi.com/bluetooth) or contact your mobile service provider for the compatibility test and further information.

<sup>2</sup> Google and the Google logo are registered trademarks of Google Inc.



If you want to experience the full diversity of Audi connect, scan this QR code using your smartphone. Or follow this link in your browser: [www.audi.com/audiconnecta5](http://www.audi.com/audiconnecta5)

## Mobility & navigation



**Point-of-interest search (POI); with additional voice control for the A5/S5 Coupé**  
in Google™ database<sup>2</sup>



**Traffic information online**  
Detailed information on traffic flows, e.g. for individual stretches of road; faster and more precise information on the occurrence and clearing of traffic jams



**Navigation with Google Earth™ mapping service<sup>2</sup> and Google Street View™<sup>2</sup>**  
with high-resolution (30 m zoom) aerial and satellite images, photos, commercial entries, etc.



**Fuel prices**  
The cheapest petrol stations at your destination or in the vicinity



**Parking information**  
Help with looking for car parks and multi-storeys incl. price details. And – if available – details about vacant spaces

## Communication



**Wi-Fi hotspot**  
connects your mobile devices to the internet

## Infotainment



**Weather**  
Charts and weather maps relating to the destination



**Audi music stream**  
Access to global radio stations via smartphone app and Wi-Fi connection



**News online**  
Text and images about current world events



**City events**  
Up-to-date information about events e.g. in your vicinity or at your destination



**Travel information**  
Professionally prepared sightseeing information, with read-aloud and import function directly to your navigation destination



**myAudi – your personal “control-centre”**  
Put your own personal route together at home and send it to your Audi MMI. Destinations can be entered via [audi.com/myaudi](http://audi.com/myaudi), via the **myAudi mobile assistant** app or via **Google Maps™<sup>2</sup>**.



# You sit at the wheel.

Others are working in the background.

Most road accidents are caused by human error. In many cases, the results of accidents can be reduced by modern assistance systems. Audi puts various different technologies to work to help you reach your destination safely. The assistance systems work closely together, which increases their versatility and performance – and makes your trip more comfortable at the same time.

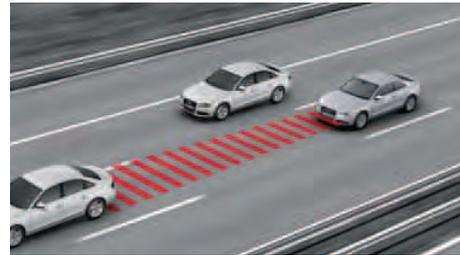

**adaptive cruise control\***: The automatic distance control detects vehicles ahead by means of a radar sensor. Within system limits, the vehicle brakes and accelerates automatically, keeping the distance set by the driver to the traffic ahead constant.

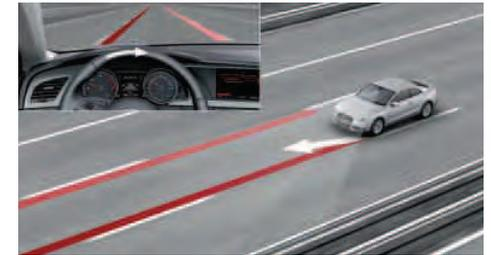

**Audi active lane assist\*** helps to keep you in lane when travelling at speeds from about 60 to 250 km/h for instance by applying a gentle corrective steering movement. There are two respective system settings for you to choose from in the MMI (steering point early or late).



**Audi side assist\*:** The lane change assistant helps you to change lanes. From a speed of around 30 km/h, it monitors the area alongside and behind the vehicle. Radar sensors at the rear detect any vehicles that may be in the blind spot or approaching quickly from behind. If Audi side assist deems that a detected vehicle will compromise a lane change, it signals this by means of an LED display on the corresponding exterior mirror.

**Please note:** The systems can only work within system limits. They can be of assistance, but drivers are still required to be attentive at all times.

\*Optional equipment.





It is the equipment that turns an Audi into your Audi.

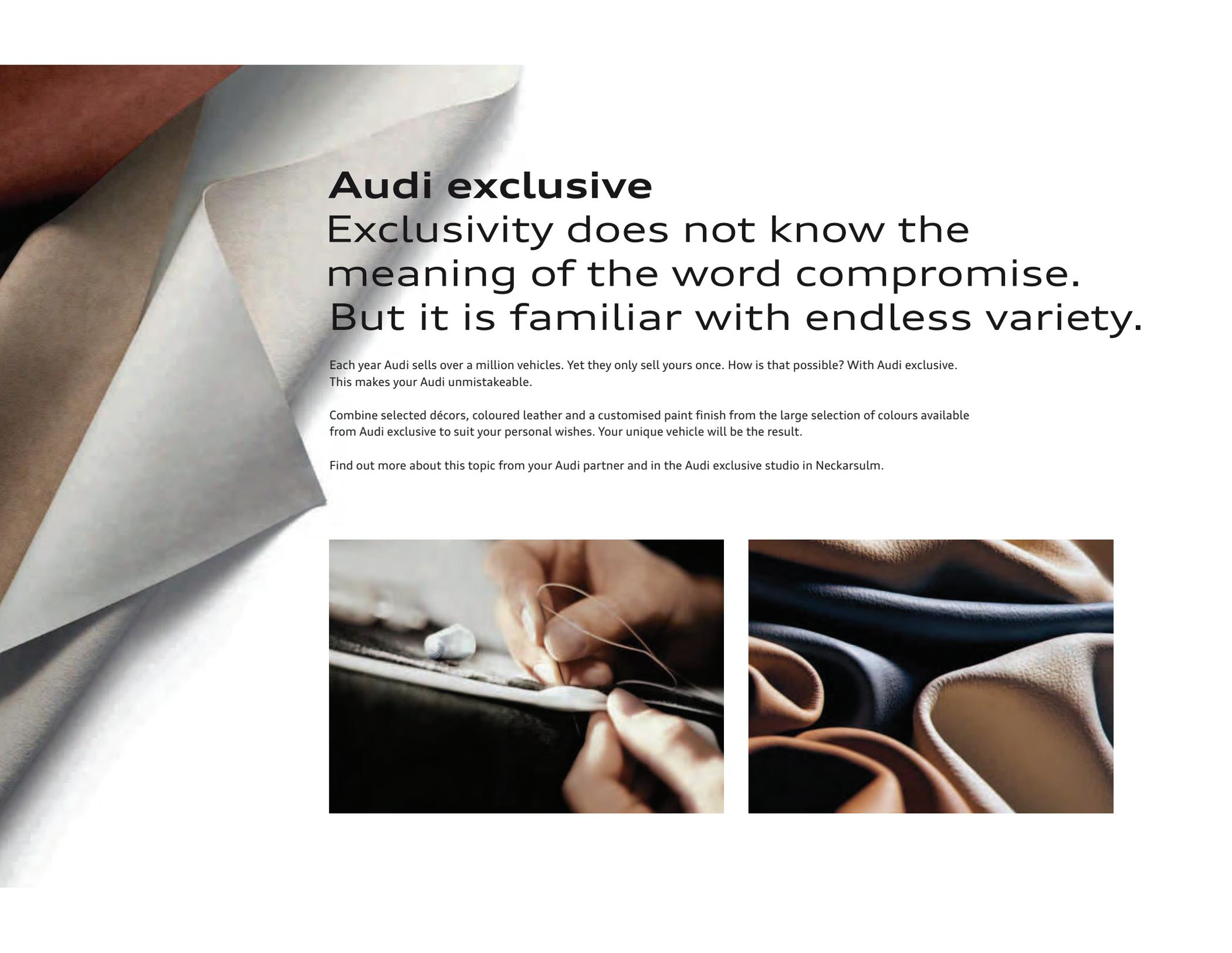

# **Audi exclusive**

## Exclusivity does not know the meaning of the word compromise. But it is familiar with endless variety.

Each year Audi sells over a million vehicles. Yet they only sell yours once. How is that possible? With Audi exclusive. This makes your Audi unmistakable.

Combine selected décors, coloured leather and a customised paint finish from the large selection of colours available from Audi exclusive to suit your personal wishes. Your unique vehicle will be the result.

Find out more about this topic from your Audi partner and in the Audi exclusive studio in Neckarsulm.

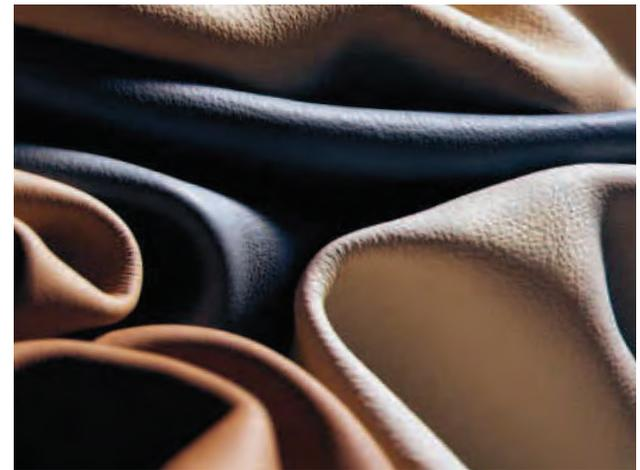
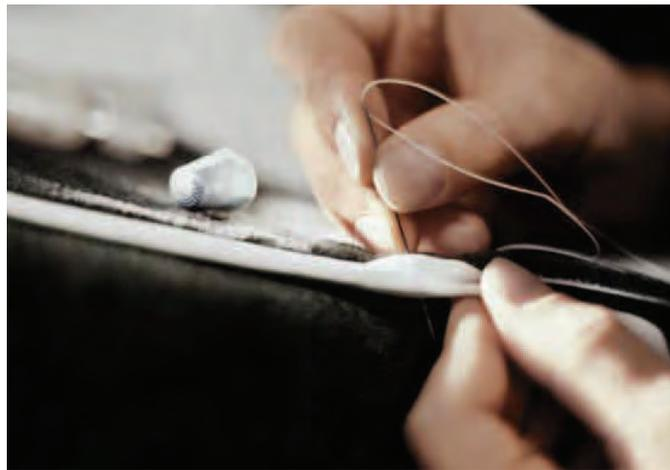



Audi exclusive leather upholstery and trim (package 2) in Valcona leather in alabaster white/Havana brown with coloured stitching in orange, floor mats in Havana brown with alabaster white leather piping, orange stitching, wood inlays in fine grain myrtle, nutmeg. From quattro GmbH



Sport seats, front, with two-colour seat upholstery in cloudy grey/black with piping in fine Nappa leather and coloured stitching to match the seat centre panel, inlays in aluminium/Beaufort, black. From quattro GmbH

### Two-colour seat upholstery



Fine Nappa leather, cognac/black

### Inlays



Matt brushed aluminium

### Audi exclusive line\*

#### Sport seats, front

#### Electric lumbar support for the front seats

#### Two-colour seat upholstery with piping and coloured stitching

seat side bolsters and head restraints black/seat centre panel and piping with stitching in a choice of cognac, alabaster white, cloudy grey (only for A5 Coupé) or crimson red (only for A5 Cabriolet); in Fine Nappa leather; for A5 Cabriolet also including heat protection for the front seats

#### Door trims

door trim inserts in fine Nappa leather (to match seat centre panel) and leather-covered armrests in the doors in black with coloured stitching (to match seat centre panel)

#### Leather-covered sport steering wheel in 3-spoke design

with coloured stitching (to match seat centre panel); optional: leather-covered multifunction sport steering wheel in 3-spoke design with or without shift paddles with coloured stitching (to match seat centre panel)

#### Gear or selector lever gaiter

with coloured stitching (to match seat centre panel)

#### Inlays

matt brushed aluminium; optional: piano finish, black, aluminium/Beaufort, black (including surround for instrument cluster in piano finish look, black) or walnut, dark brown

#### Black interior

headlining in black cloth; for A5 Cabriolet including black attachments

#### Floor mats

with coloured piping (to match seat centre panels)

#### Audi exclusive door sill trims



Fine Nappa leather, alabaster white/black

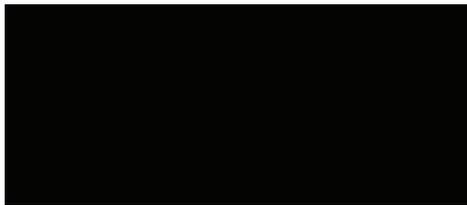

Piano finish, black



Fine Nappa leather, cloudy grey/black  
(only available for A5 Coupé)



Walnut, dark brown



Fine Nappa leather, crimson red/black  
(only available for A5 Cabriolet)



Aluminium/Beaufort, black



Coloured piping and stitching to match seat centre panel



Gear lever gaiter with coloured stitching to match seat centre panel

\* From quattro GmbH.

## S line. Visibly more sportiness.

Driving an Audi A5 Coupé/A5 Cabriolet is a clear commitment to automotive sportiness. The S line packages allow you to enhance the athletic appearance of your Audi A5 Coupé/A5 Cabriolet even more: with a range of equipment that accentuates its dynamic body line, gives its interior a perceptibly sporty identity and further enhances its driving performance. Decide on a plus in sportiness.





**S line exterior package**

**Front and rear bumpers, side grilles and diffuser insert**  
in a striking, sporty design

**Side sill trims**  
painted in body colour

**Diffuser insert**  
painted in platinum grey

**S line logos**  
on the front wings and door sill trims



Front bumper and side radiator grilles in a distinctive sporty design



Diffuser insert painted in platinum grey



Sport seats, front, in sprint cloth/leather, black with contrasting stitching and inlays in matt brushed aluminium



S line leather-covered multifunction sport steering wheel in 3-spoke design



Gear lever knob in perforated leather

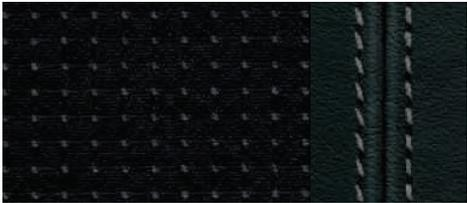
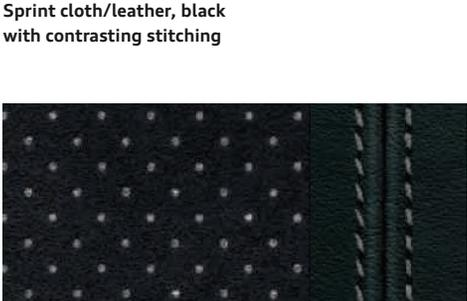
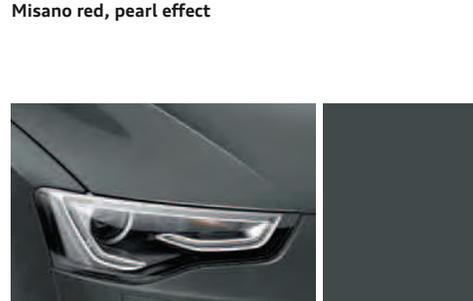
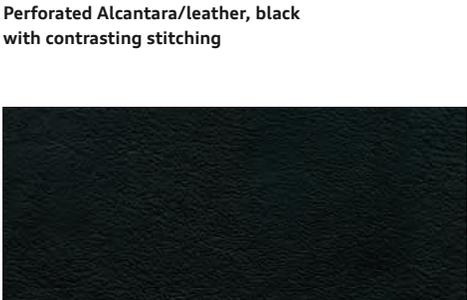

Audi exclusive cast aluminium wheels in 5-twin-spoke design

Seat upholstery	Additional exterior paint finish options	S line sport package
		<p><b>The S line sport package includes the following equipment:</b></p> <p><b>Audi exclusive cast aluminium wheels in 5-twin-spoke design</b> size 8.5 J x 18 with 245/40 R 18 tyres*</p> <p><b>S line sport suspension</b> with more dynamic suspension tuning and vehicle lowered by a further 10 mm compared with the dynamic suspension and the sport suspension</p> <p><b>S line logos</b> on the door sill trims and the front wings</p> <p><b>Interior, dashboard and headlining</b> in black with contrasting stitching on seat upholstery, leather-covered sport steering wheel, gear or selector lever gaiter and floor mats (with sprint cloth/leather and perforated Alcantara/leather)</p> <p><b>Sport seats, front</b> including electric lumbar support</p> <p><b>S line leather-covered sport steering wheel in 3-spoke design</b> in black leather (steering wheel grips in perforated leather) with S line emblem</p> <p><b>Gear or selector lever knob</b> in perforated black leather</p> <p><b>Inlays</b> in matt brushed aluminium</p> <p><b>Optional available:</b></p> <p><b>Further wheels in size 18 inch (or larger)</b></p> <p><b>S sport seats, front with seat upholstery in fine Nappa leather</b> in black, with S line embossing on the front-seat backrests</p>
		<p><b>The following options are available for the seat upholstery:</b></p> <p><b>S line seat upholstery in sprint cloth/leather, perforated Alcantara/leather or fine Nappa leather</b> each in black with S line embossing on the front-seat backrests; available in further colours in combination with Audi exclusive line (without S line embossing on the front-seat backrests, steering wheel without S line emblem and not perforated, contrasting stitching according to the Audi exclusive line range)</p> <p><b>S line leather-covered multifunction sport steering wheel in 3-spoke design, as an option flattened at the bottom</b> each in black leather (steering wheel grips in perforated leather) with S line emblem; models with automatic transmission optionally have shift paddles behind the steering wheel</p>
		<p><b>Inlays</b> Piano finish, black, stainless steel mesh (centre console in piano finish, black), aluminium/Beaufort, black or fine grain birch, grey; inlays in piano finish, black, aluminium/Beaufort, black or stainless steel mesh also include an instrument cluster surround in piano finish look, black</p>
<p><b>Fine Nappa leather, black</b></p>		<p><b>Paint finishes available in all standard/optional colours and in the special colours Misano red, pearl effect or Daytona grey, pearl effect</b></p>

\*You will find specifications on the technical characteristics of tyres on page 127.



A5 Coupé in glacier white, metallic, with cast aluminium wheels in 5-V-spoke design.  
Equipment: sport seats, front, in Milano leather, chestnut brown, inlays in fine grain ash, natural brown, symphony radio and Bang & Olufsen Sound System





A5 Coupé in monsoon grey, metallic, with cast aluminium wheels in 5-arm Y design.  
Equipment: climate-controlled comfort seats, front, in Milano leather, velvet beige, inlays in walnut, dark brown, MMI navigation plus and Bang & Olufsen Sound System





A5 Cabriolet in scuba blue, metallic, with cast aluminium wheels in 15-spoke star design. Equipment: sport seats, front, in Milano leather, lunar silver, inlays in aluminium Trigon, symphony radio and Bang & Olufsen Sound System





A5 Cabriolet in cuvée silver, metallic, with brown hood and with cast aluminium wheels in 5-arm design.  
Equipment: sport seats, front, in Milano leather, black, headroom heating, inlays in aluminium Trigon,  
MMI navigation plus and Bang & Olufsen Sound System



Solid paint finishes



Ibis white

Metallic paint finishes



Glacier white, metallic



Monsoon grey, metallic



Volcano red, metallic



Brilliant red



Ice silver, metallic



Dakota grey, metallic



Shiraz red, metallic



Brilliant black



Cuvée silver, metallic



Teak brown, metallic



Scuba blue, metallic

The model-specific standard and optional equipment can be found in the index from page 130 onwards.

**Metallic paint finishes**



Moonlight blue, metallic

**Pearl effect paint finishes**



Misano red, pearl effect

**Crystal effect paint finish**



Estoril blue, crystal effect

**Customised paint finishes**



Audi exclusive customised paint finishes  
From quattro GmbH



Lava grey, pearl effect



Phantom black, pearl effect



Cast aluminium wheels in 10-spoke design

The model-specific standard and optional equipment can be found in the index from page 130 onwards.

Wheels/tyres



**Forged aluminium wheels in 6-arm design**  
size 7.5 J x 17 with 225/50 R 17 tyres<sup>1</sup>



**Cast aluminium wheels in 7-arm parabolic design**  
size 7.5 J x 17 with 225/50 R 17 tyres<sup>1</sup>



**Cast aluminium wheels in 15-spoke star design**  
size 8.5 J x 18 with 245/40 R 18 tyres<sup>1</sup>



**Audi exclusive cast aluminium wheels in 10-spoke design**  
size 8.5 J x 18 with 245/40 R 18 tyres<sup>1</sup>.  
From quattro GmbH



**Cast aluminium wheels in 5-arm design**  
size 7.5 J x 17 with 220/50 R 17 tyres<sup>1</sup>



**Cast aluminium wheels in 5-arm dynamic design**  
size 8.5 J x 18 with 245/40 R 18 tyres<sup>1</sup>



**Cast aluminium wheels in 5-parallel-spoke design (S design)**  
size 8.5 J x 18 with 245/40 R 18 tyres<sup>1</sup>



**Audi exclusive cast aluminium wheels in 10-spoke design**  
size 8.5 J x 18 with 245/40 R 18 tyres<sup>1</sup>.  
From quattro GmbH



**Cast aluminium wheels in 6-spoke parabola design**  
size 8 J x 17 with 245/45 R 17 tyres<sup>1</sup>  
(optionally available with run-flat tyres)



**Cast aluminium wheels in 5-V-spoke design**  
size 8.5 J x 18 with 245/40 R 18 tyres<sup>1</sup>



**Audi exclusive cast aluminium wheels in 5-twin-spoke design**  
size 8.5 J x 18 with 245/40 R 18 tyres<sup>1</sup>.  
From quattro GmbH



**Cast aluminium wheels in 5-arm Y design**  
size 8.5 J x 19 with 255/35 R 19 tyres<sup>1</sup>

<sup>1</sup>You will find specifications on the technical characteristics of tyres on page 127.

**Wheels/tyres**



**Lightweight wheels in aluminium composite construction, 5-arm Y design, galvano grey metallic, matt<sup>2</sup>**  
size 8.5 J x 19 with 255/35 R 19 tyres<sup>1</sup>



**Audi exclusive cast aluminium wheels in 5-segment-spoke design**  
size 9 J x 19 with 255/35 R 19 tyres<sup>1</sup>.  
From quattro GmbH



**Audi exclusive cast aluminium wheels in 7-twin-spoke design**  
size 9 J x 20 with 265/30 R 20 tyres<sup>1</sup>.  
From quattro GmbH



**Cast aluminium winter wheels in 5-parallel-spoke design (S design)**  
size 8 J x 18 with 245/40 R 18 tyres<sup>1</sup>, permissible top speed 240 km/h, can be fitted with snow chains



**Cast aluminium wheels in 10-spoke design**  
size 8.5 J x 19 with 255/35 R 19 tyres<sup>1</sup>



**Audi exclusive cast aluminium wheels in 5-arm rotor design, in matt titanium look, high-gloss turned finish**  
size 9 J x 19 with 255/35 R 19 tyres<sup>1</sup>.  
From quattro GmbH



**Forged aluminium winter wheels in 6-arm design**  
size 7.5 J x 17 with 225/50 R 17 tyres<sup>1</sup>, permissible top speed 210 km/h, can be fitted with snow chains (optionally available with run-flat tyres)

**Run-flat tyres**

Journey can be continued on a flat tyre at a speed of up to 80 km/h and for a maximum distance of 30 km, without having to change the wheel.

**Anti-theft wheel bolts**

can only be loosened using adapter provided

**Tyre repair kit**

with 12V compressor and tyre sealant, permissible top speed 80 km/h

**Space-saving spare wheel**

**Tyre pressure loss indicator**

visual and acoustic warning if the pressure drops in one or more tyres; display in the driver information system

**Vehicle tool kit**

in the luggage compartment

**Vehicle jack**

in the luggage compartment



**Cast aluminium wheels in 5-parallel-spoke star design (S design)**  
size 8.5 J x 19 with 255/35 R 19 tyres<sup>1</sup>



**Audi exclusive cast aluminium wheels in 20-spoke design**  
2-piece, size 9 J x 19 with 255/35 R 19 tyres<sup>1</sup>.  
From quattro GmbH



**Cast aluminium winter wheels in 5-V-spoke design**  
size 8.5 J x 18 with 245/40 R 18 tyres<sup>1</sup>, permissible top speed 240 km/h, cannot be fitted with snow chains

**Hood colours**

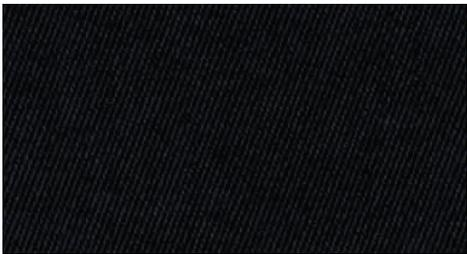

Hood, black



Hood, red



Hood, grey



Hood, brown

**Hood linings**

**Hood linings**  
A5/S5 Cabriolet: in a choice of black or star silver;  
A5 Cabriolet: with velvet beige seats in pashmina beige

<sup>1</sup>You will find specifications on the technical characteristics of tyres on page 127. <sup>2</sup>For information on when this feature will be available, please contact your Audi partner.



**Standard seats, front**

with manual adjustment of seat height, fore/aft position, backrest angle, head restraint height; convenience entry, enhanced front-seat folding function for easy access to the rear compartment.  
(The image shows standard seat, front, in fine Nappa leather, titanium grey.)

**Cloth upholstery and trim**

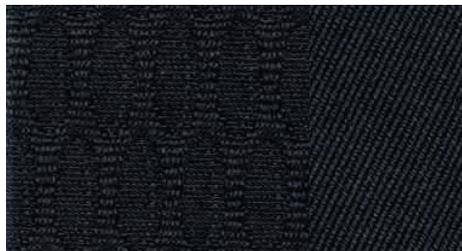

**Arcade cloth, black**

**Leather upholstery and trim**



**Milano leather, black**

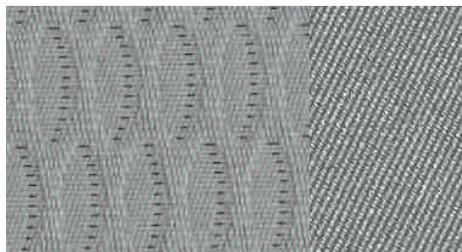

**Arcade cloth, titanium grey**

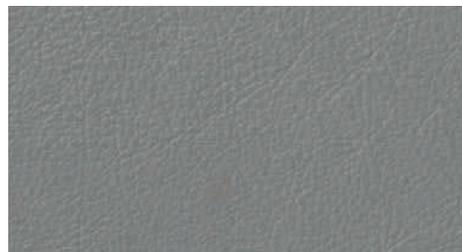

**Milano leather, titanium grey**



**Arcade cloth, velvet beige**  
with moor brown interior equipment



**Milano leather, velvet beige**  
with moor brown or black interior equipment;  
for A5 Cabriolet with moor brown interior equipment

Leather upholstery and trim



Fine Nappa leather, black



Audi exclusive leather upholstery and trim  
From quattro GmbH



Fine Nappa leather, titanium grey



Fine Nappa leather, chestnut brown



**Sport seats, front**

with manual adjustment (electric adjustment on S5 Coupé/S5 Cabriolet) for seat height, fore/aft position, seat cushion angle, backrest angle; manual adjustment for head restraint height; with shaped seat side bolsters for improved lateral support when cornering, extendable thigh support and electric 4-way lumbar support; convenience entry: enhanced front-seat folding function for easy access to the rear compartment; for A5 Coupé/A5 Cabriolet with S line sport package includes S line embossing on the front-seat backrests; for S5 Coupé/S5 Cabriolet includes S5 embossing.

(The image shows sport seat, front, in Alcantara/leather, black with electric seat adjustment.)

The model-specific standard and optional equipment can be found in the index from page 130 onwards.

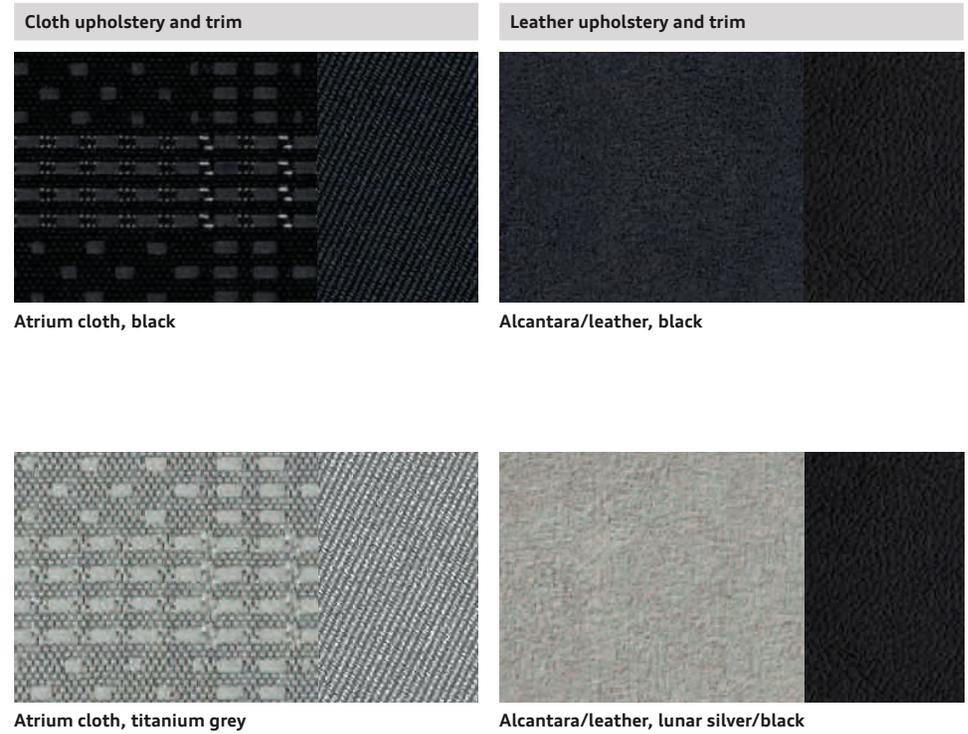

Leather upholstery and trim



Alcantara/leather, lunar silver



Milano leather, black



Fine Nappa leather, black



Fine Nappa leather, lunar silver



Alcantara/leather, titanium grey



Milano leather, titanium grey

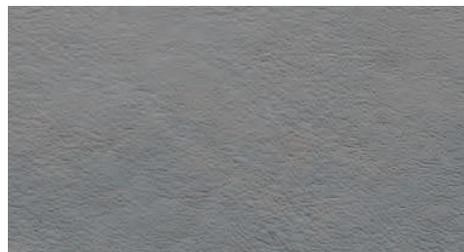

Fine Nappa leather, titanium grey



Fine Nappa leather, garnet red



Alcantara/leather combination, velvet beige  
with moor brown interior equipment



Milano leather, velvet beige  
with moor brown or black interior equipment;  
for A5 Cabriolet with moor brown interior equipment



Fine Nappa leather, velvet beige  
with moor brown or black interior equipment;  
for A5 Cabriolet with moor brown interior equipment



Fine Nappa leather, red

\* Optional equipment; standard with S5.

Leather upholstery and trim



Fine Nappa leather, chestnut brown



Audi exclusive leather upholstery and trim  
From quattro GmbH



Fine Nappa leather, Chennai brown



**S sport seats, front**

with electric adjustment for seat height, fore/aft position, seat cushion angle, backrest angle; with shaped seat side bolsters for improved lateral support when cornering, extendable thigh support and electric 4-way lumbar support; with integral head restraints; for A5 Coupé/A5 Cabriolet with S line sport package includes S line embossing on the front-seat backrests; for S5 Coupé/S5 Cabriolet includes S5 embossing and contrasting stitching; convenience entry: enhanced front-seat folding function for easy access to the rear compartment; for A5/S5 Coupé rear bench seat with integrated centre storage tray; for A5/S5 Cabriolet includes cup holder integrated in the rear bench seat with cover.

(The image shows S sport seat, front, in fine Nappa leather, magma red/black with contrasting stitching.)

**Leather upholstery and trim**



**Fine Nappa leather, black with black stitching**



**Fine Nappa leather, chestnut brown/black with contrasting stitching**



**Fine Nappa leather, black with black stitching**



**Fine Nappa leather, magma red/black with contrasting stitching**

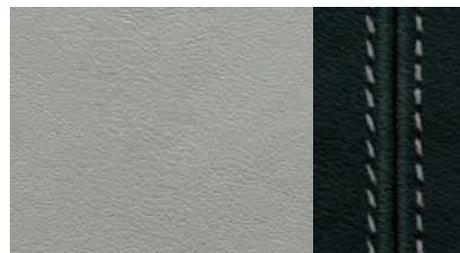

**Fine Nappa leather, black with contrasting stitching**



**Audi exclusive leather upholstery and trim**  
From quattro GmbH



Leather upholstery

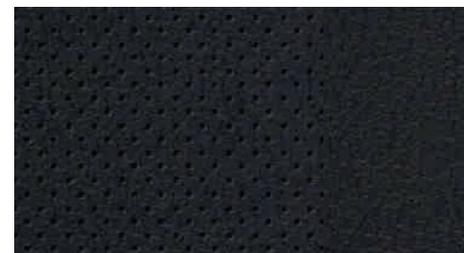

Perforated Milano leather, black

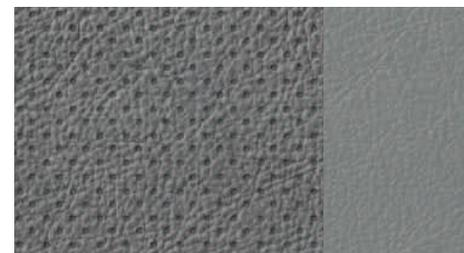

Perforated Milano leather, titanium grey

**Climate-controlled comfort seats, front**

exclusive seat option with shaped seat side bolsters and soft-feel design for luxurious comfort; actively ventilated and heated seat and backrest centre panels, automatically heated to prevent cold seats; perforated leather on the ventilated seat cushions of the front seats and on the non-ventilated seat cushions of the two outer rear seats; convenience entry: enhanced front-seat folding function to facilitate easy access to the rear compartment; rear bench seat of the A5/S5 Coupé has integrated centre storage tray.

(The image on the left shows the climate-controlled comfort seat, front for the A5/S5 Coupé in perforated Milano leather, chestnut brown; the image on the right shows the climate-controlled comfort seat, front for the A5/S5 Cabriolet in perforated Milano leather, chestnut brown.)

The model-specific standard and optional equipment can be found in the index from page 130 onwards.

## Leather upholstery and trim



Perforated Milano leather, chestnut brown

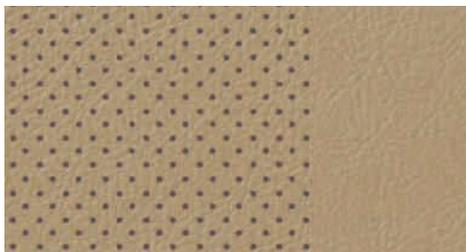

Perforated Milano leather, velvet beige  
with moor brown or black interior equipment;  
for A5 Cabriolet with moor brown interior equipment



Audi exclusive leather upholstery and trim  
From quattro GmbH

## Cloth/leather upholstery and trim, headlining

### Arcade cloth upholstery and trim

seat centre panels in arcade cloth, seat side bolsters, head restraints, front centre armrest (if ordered) and door and side panel inserts in single-colour cloth

### Atrium cloth upholstery and trim

seat centre panels in atrium cloth, seat side bolsters, head restraints, front centre armrest (if ordered), door and side panel inserts and thigh support in single-colour cloth

### Alcantara/leather combination

seat centre panels and door and side panel inserts in Alcantara; seat side bolsters, head restraint centre panels and front centre armrest (if ordered) in leather; for A5 Coupé/A5 Cabriolet with S line sport package includes S line embossing on the front-seat backrests; for S5 Coupé/S5 Cabriolet with S5 embossing on the front-seat backrests; for A5/S5 Cabriolet including heat protection

### Milano leather upholstery and trim

seat centre panels, seat side bolsters, head restraint centre panels and front centre armrest (if ordered) in Milano leather; for A5 Cabriolet includes heat protection

### Perforated Milano leather upholstery and trim

seat centre panels of the front seats and non-ventilated seat centre panels of the two outer rear seats in perforated Milano leather; seat side bolsters and head restraint centre panels in Milano leather; for A5/S5 Cabriolet includes heat protection

### Fine Nappa leather upholstery and trim

seat centre panels, seat side bolsters, head restraints, front centre armrest (if ordered), door and side panel inserts and door armrests in fine Nappa leather; for A5 Coupé/A5 Cabriolet with the S line sport package includes S line embossing on the front-seat backrests; for S5 Coupé/S5 Cabriolet with contrasting stitching and S5 embossing on the front-seat backrests; for A5/S5 Cabriolet includes heat protection

### Audi exclusive leather upholstery and trim (package 1) in Alcantara/Valcona leather

seat side bolsters, head restraints, door armrests and front centre armrest (if ordered) in Valcona leather, seat centre panels and door trim inserts in Alcantara. Individual choice of colour for the leather, Alcantara and decorative stitching from the range of Audi exclusive colours. (Can only be ordered in conjunction with sport seats, front and S sport seats, front.) From quattro GmbH

### Audi exclusive leather upholstery and trim (package 1) in Valcona leather

seat upholstery, head restraints, door trim inserts, door armrests and front centre armrest (if ordered) in Valcona leather. Individual choice of colour for the leather and decorative stitching from the range of Audi exclusive colours. From quattro GmbH

### Audi exclusive leather upholstery and trim (package 2) in Valcona leather

leather-covered in addition to package 1: backrest covers. Individual choice of colour for the leather and the decorative stitching from the range of Audi exclusive colours. Attachments are matched to the colour of the leather. From quattro GmbH

### Audi exclusive leather upholstery and trim (package 2) in Alcantara/fine Nappa leather

seat centre panels and door trim inserts in Alcantara, seat side bolsters, head restraints, front centre armrest (if ordered), backrest covers, door armrests in fine Nappa leather, including heat protection for the seat cushions and backrests of the front seats. Individual choice of colour for the leather, Alcantara and decorative stitching from the Audi exclusive range of colours. Attachments are matched to the colour of the leather. (Can only be ordered in conjunction with sport seats, front and S sport seats, front.) From quattro GmbH

### Audi exclusive leather upholstery and trim (package 2) in fine Nappa leather

seat upholstery, head restraints, door trim inserts and front centre armrest (if ordered), backrest covers, door armrests in fine Nappa leather, includes heat protection for the seat cushions and backrests of the front seats. Individual choice of colour for the leather and decorative stitching from the range of Audi exclusive colours. Attached parts are colour-matched to the colour of the leather. From quattro GmbH

### Headlining in cloth

depending on the colour selected for interior trim; in lunar silver or pashmina beige for the A5 Coupé; in lunar silver or black for the S5 Coupé

### Headlining in black cloth

**Inlays**



**Reflex finish, steel grey**



**Matt brushed aluminium**

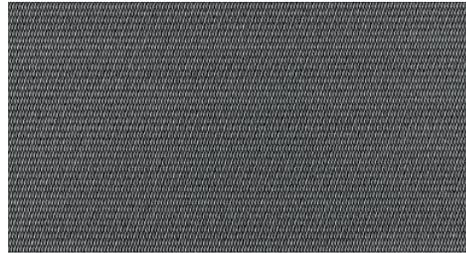

**Stainless steel mesh**  
centre console in piano finish, black. Surround for instrument cluster in piano finish look, black



**Fine grain birch wood, grey**



**Reflex finish, moor brown**  
available with seat upholstery in velvet beige with moor brown interior equipment

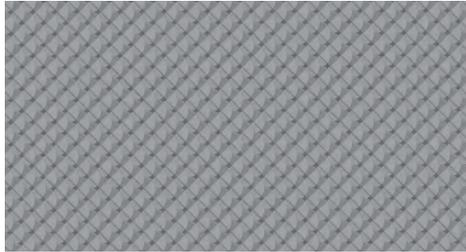

**Aluminium Trigon**

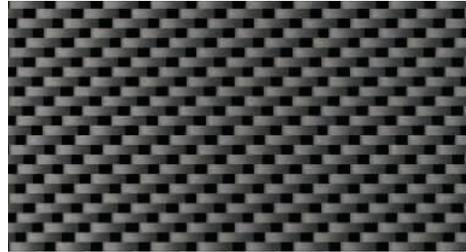

**Carbon Atlas**



**Walnut, dark brown**

## Inlays



**Fine grain ash, natural brown**



**Aluminium/Beaufort, black**  
instrument cluster surround in piano finish look, black.  
From quattro GmbH



**Audi exclusive inlays**  
From quattro GmbH



**Oak Beaufort, light brown**



**Piano finish, black**  
surround for instrument cluster in piano finish look,  
black. From quattro GmbH

## Inlays

for door and side panel trims and the centre console if the front centre armrest has also been ordered

### Audi exclusive inlays

available in fine grain ash, nougat, oak sepia and fine grain myrtle, nutmeg. From quattro GmbH

### Inlays in oak Beaufort, light brown

Oak Beaufort is produced using a sophisticated process and consists of layered oak wood in a 2-colour design. In visual terms, this inlay is reminiscent of the styling of a yacht.

### Inlays in aluminium/Beaufort, black

Aluminium/Beaufort is produced using a sophisticated process and consists of aluminium layered with blackened wood. This unusual combination of materials unites natural elements with dynamism. From quattro GmbH

Lights



**Headlights**

halogen headlights using free-form technology with clear glass cover, electric headlight range control and parking light function, daytime running lights with separate reflectors

**adaptive light**

comprising a dynamic cornering light and static turning light: the dynamic cornering light determines the course of the road from the movement of the steering wheel and variably illuminates corners by swivelling the xenon headlights. It is operational between speeds of approx. 10 km/h and 110 km/h. The static turning light switches on automatically when the indicator has been engaged for a while at low vehicle speeds and illuminates the new direction in which the vehicle is driving.

**Daytime running lights**

with xenon plus daytime running light strip in homogeneous LED technology with low power consumption, integrated into the headlights; with separate reflectors for A5 Coupé/Cabriolet



**xenon plus**

Headlights utilising durable gas discharge technology for dipped and high beam ensure intensive illumination of the road and provide good uniformity and range. The automatic dynamic headlight range control prevents oncoming traffic from being dazzled. The homogeneous daytime running light strip uses LED technology and has low power consumption; includes headlight cleaning system

**Headlight cleaning system**

uses water and high pressure for improved illumination and good visibility due to reduced scatter

**High-beam assist**

working within system limits, automatically detects the headlights of oncoming traffic, the rear lights of other road users and built-up areas. Depending on the traffic situation, the high beam is automatically switched on or off. The system thereby improves the driver's visibility and ensures a more relaxed drive thanks to the extra comfort and convenience; includes light/rain sensor



**LED rear lights**

LED brake, rear, indicator, rear fog and rear number plate lights; low power consumption

**Rear lights**

in red, reversing lights in white, integrated rear fog lights; LED rear number plate lights

**Interior lighting**

at front, including front reading lights; with delayed switch-off and contact switches on all doors; reflected lighting for the centre console and the vanity mirror and luggage compartment lighting; for A5/SS Coupé an additional interior light at the rear and courtesy lighting in the tailgate

**Lighting package**

anti-glare lighting for the passenger compartment using energy-saving, durable LED technology; comprising: footwell lighting at the front and illuminated inside door handles and vent controls; bulb lighting for: glove compartment, entrance lighting at front and active door reflectors; for A5/SS Coupé reading lights at rear



**Front fog lights**

integrated in the bumper, for improved illumination of the road in poor visibility

**Light/rain sensor**

for controlling the automatic headlights and the automatic wiper function; includes coming home/leaving home function: delayed switching-off/automatic switching-on of the front fog lights, rear and number plate lights and, in conjunction with xenon plus, the LED daytime running lights, when parking/opening the vehicle; includes windscreen with grey strip along the top edge

## Mirrors

**Exterior mirrors with integrated LED indicator**  
electrically adjustable, convex, flat or aspherical mirror glass, housing painted in body colour; housing in aluminium look for the S5 Coupé/S5 Cabriolet

also optionally:

**heated**  
including heated windscreen washer jets

**heated and electrically folding**  
including heated windscreen washer jets and automatic kerb-side function for the exterior mirror on the passenger side

**heated and electrically folding and automatically dimming on both sides**  
including heated windscreen washer jets and automatic kerb-side function for the exterior mirror on the passenger side

**heated and electrically folding, automatically dimming on both sides, with memory function**  
including heated windscreen washer jets and automatic kerb-side function for the exterior mirror on the passenger side, exterior mirrors also with memory function

The automatic kerb-side function tilts the mirror on the passenger side downwards when reverse gear is engaged, giving the driver an optimum view of the kerb.

**Interior mirror**  
dimming

optionally:

**automatically dimming**  
including windscreen with grey strip; additionally for A5/S5 Coupé acoustic glazing for improved windscreen insulation and reduced noise from outside; with light/rain sensor

## Roof systems



**Panoramic tilt sunroof**  
electrically operated, made from tinted single-glazed safety glass with manually adjustable sunscreen, convenience locking/opening from outside via vehicle key

**Hood**  
fully automatic, made from insulated 3-ply fabric, hood actuation up to a speed of 50 km/h

**Acoustic hood**  
fully automatic, due to optimised material thickness and connection, the noise level in the interior is clearly improved, including vanity mirror illumination, interior front and rear compartment light in LED technology

**Wind deflector**  
can be stowed away in the luggage compartment in the spare wheel well, as long as the space-saving wheel is not ordered

## Closing systems

**Electronic immobiliser**  
integrated in the engine control unit, automatically activated by the vehicle key

**Anti-theft alarm**  
including interior monitoring system and tow-away protection via angle of inclination sensor; can be deactivated; signal horn for monitoring the doors, bonnet and luggage compartment lid independent of vehicle electrical system

**Preparation for tracking system**  
preparation for connecting a tracking system (available from Audi Genuine Accessories) that enables a stolen vehicle to be located

**Ignition lock**  
electronic, vehicle key features integrated chip, automatically stores relevant vehicle service data (mileage, chassis number and much more)

**Luggage compartment lid, automatically opening**  
When the luggage compartment is released by the vehicle key, the button in the driver's door or by the soft-touch release on the luggage compartment lid, the luggage compartment lid automatically swings open.

**Remote control key**  
opens and locks doors, luggage compartment lid and tank flap; convenience closing/opening function for windows; including glove compartment lock for A5/S5 Cabriolet; with S5 emblem for S5 Coupé/Cabriolet

### Closing systems



#### Convenience key

access and authorisation system; the key only needs to be carried with you; the engine is started and switched off via the engine start-stop button on the centre console, the vehicle is locked and unlocked from outside via sensors on all door handles. The luggage compartment lid can also be opened when the vehicle is locked; for A5/S5 Cabriolet convenience closing/opening of hood via the vehicle key within an approx. 4 m radius of the vehicle; with S5 emblem for S5 Coupé/S5 Cabriolet

#### Garage door opener (HomeLink)

programmable radio-operated remote control, control buttons integrated in the interior lighting module; can be used to open many garage doors and exterior gates; control of safety and lighting systems possible; in conjunction with MMI navigation plus with programming assistance provided by the MMI and set-up assistance from appropriate logbook information on the screen. (For information on compatible hand-held transmitters, please contact your Audi partner or visit [www.eurohomelink.com](http://www.eurohomelink.com).)

### Glazing

#### Heat-insulating glass

green tinted, windscreen made of laminated glass; heated rear window with timer switch

#### Dark-tinted windows (privacy glazing)

dark-tinted rear window and rear side windows

#### Windscreen cleaning system

2-speed operation, 4-speed adjustable intermittent wipe, flick-wipe function, automatic wash/wipe function

#### Sun visors

for driver and front passenger, can be folded and swivelled, includes vanity mirror

#### Sunblind, electric for the rear window

### Further exterior equipment

#### Provision for trailer towing hitch

includes preparation of control units and enhanced engine cooling. The trailer towing hitch for retrofitting is available from Audi Genuine Accessories.

#### Trailer towing hitch

removable and lockable, ball bar and ball head made from forged steel, the 13-pin socket can be swivelled out of sight behind the bumper skirt, when removed, the trailer towing hitch can be stored in the spare wheel well; includes trailer stabilisation system via Electronic Stabilisation Control (ESC)

#### High-gloss package

Roof frame and window slot trim in anodised aluminium

#### Aluminium-look exterior

Surface of windscreen frame, window slot trim and cover strip in anodised aluminium

#### Audi exclusive high-gloss package, black

radiator grille frame in high-gloss black, number plate holder and radiator protective grille in matt black, inserts on radiator protective grille and side air intakes in high-gloss black, roof frame and window slot trim in high-gloss black.

From quattro GmbH

#### Bumpers, body-coloured (S-specific)

front and rear and featuring a sporty, dynamic design with S rear diffuser and rear blade in aluminium look

#### Audi Singleframe

radiator grille in high-gloss black; for S5 Coupé/S5 Cabriolet in platinum grey with chrome struts

#### Exhaust tailpipes

A5 Coupé:  
single-branch design, 2 tailpipes on the left for the 1.8 TFSI, 2.0 TFSI, 2.0 TDI and 3.0 TDI clean diesel with chrome-plated surrounds;  
dual-branch design with one tailpipe each left and right for the 3.0 TFSI and 3.0 TDI with chrome-plated surrounds

A5 Cabriolet:  
single-branch design, 2 tailpipes on the left for the 2.0 TDI with chrome-plated surrounds;  
dual-branch design with one tailpipe each left and right for the 1.8 TFSI, 2.0 TFSI, 3.0 TFSI and 3.0 TDI with chrome-plated surrounds

S5 Coupé/S5 Cabriolet:  
dual-branch design with two oval tailpipes each on the left and right with polished surrounds

#### Rear spoiler

integrated into the luggage compartment lid

#### Model name/logo

model name (for A5 Coupé/A5 Cabriolet also the technology name) on the luggage compartment lid, quattro logo (for quattro models) on the radiator grille, on the luggage compartment lid and on the dashboard on the passenger side, on request the vehicle can also be supplied without the model name and technology name on the rear; for S5 Coupé/S5 Cabriolet S5 model name on the luggage compartment lid and the radiator grille, on the leather-covered sport steering wheel and in the rev counter; quattro logo on the dashboard on the passenger side, V6 T emblem on the front wings

#### Sill trims

for S5 Coupé/S5 Cabriolet painted in body colour

## Seats/seating comfort

### Front seats, electrically adjustable

with electric adjustment of seat height, fore/aft position, seat angle, backrest angle; electric 4-way lumbar support for the front seats; additional electric adjustment for head restraint height (not with S sport seats, front)

### Electrically adjustable front seats with memory function for driver's seat

functions as for electrically adjustable front seats, plus 2 presets for the electrically adjustable driver's seat and the exterior mirrors

### 4-way lumbar support for the front seats

electric, with horizontal and vertical adjustment

### Rear seat backrest, folding

can be split-folded 40:60 or completely, with remote backrest release in the luggage compartment; for S5 Coupé rear bench seat with integrated centre storage tray; for A5/S5 Cabriolet can be split-folded 50:50 or completely

### Seat heating, front

heats the seat and backrest centre panels; on leather upholstery and trim and sport seats also heats the seat side bolsters; individually adjustable in several stages for driver and front-passenger seats

### Seat heating, front and rear

functions as for seat heating, front, additionally for outer rear seats, individually adjustable

### Heat protection

in direct sunlight, for front seat cushions and backrests, for Alcantara/leather combination (without seat centre panels), Milano leather and fine Nappa leather. The special colour pigmentation of the leather prevents excessive build-up of heat. The infrared radiation in sunlight is reflected. The heat protection can reduce surface temperature by up to 20°C.

### Centre armrest, front

can be adjusted lengthways; with fold-open storage compartment and two 12V sockets in the centre console; for A5 Cabriolet one 12V socket in the centre console

### Centre armrest, rear

foldable

### Leather-covered armrests in the door trims and rear side panel trims in fine Nappa leather

### Head restraints

front and rear, height adjustable; for A5/S5 Cabriolet height only adjustable at the front; integrated head restraints on front S sport seats are not adjustable

### ISOFIX child seat mounting for the rear seats

standard bracket for the practical fastening of child seats in accordance with ISO standards; compatible child seats can be obtained from your Audi partner.

### ISOFIX child seat mounting for the front-passenger seat with passenger airbag deactivation switch

## Steering wheels/gear levers/controls



### Leather-covered sport steering wheel in 3-spoke design

with full-size airbag, adjustable for height and reach, includes gear or selector lever knob in leather, colour-coordinated with the selected interior trim

### Steering wheel rim in Audi exclusive leather

leather for the steering wheel rim available in all Audi exclusive colours; individual choice of colour for stitching in various Audi exclusive colours with specific Audi exclusive seam detail. From quattro GmbH

### Steering wheel rim with wooden segments

available in walnut, dark brown in 4-spoke design for leather-covered multifunction steering wheel, optionally with shift paddles. From quattro GmbH

### Audi exclusive steering wheel rim with wooden segments

available in Audi exclusive woods in 4-spoke design for leather-covered multifunction steering wheel, optionally with shift paddles. Leather and stitching available in various Audi exclusive colours; stitching on the steering wheel rim with specific Audi exclusive seam detail. From quattro GmbH



### Leather-covered multifunction sport steering wheel in 3-spoke design

with full-size airbag, adjustable for height and reach, includes gear or selector lever knob in leather, colour-coordinated with the selected interior trim; for operating available infotainment functions; models with automatic transmission optionally have shift paddles behind the steering wheel for changing gear manually; for S5 Coupé/S5 Cabriolet with S5 emblem, special S stitching and shift paddles in aluminium look

### Controls in Audi exclusive leather

leather covering of the steering wheel rim, gear/selector lever knob and gaiter available in all Audi exclusive colours; individual choice of colour for stitching in various Audi exclusive colours with specific Audi exclusive seam detail. From quattro GmbH

### Steering wheels/gear levers/controls



**Leather-covered multifunction sport steering wheel in 3-spoke design, flattened at the bottom**  
as for leather-covered multifunction sport steering wheel in 3-spoke design; additionally flattened at the bottom

**Selector lever knob in leather**  
including selector lever gaiter in leather with decorative stitching in contrasting colour

**Gear lever knob in Audi exclusive aluminium**  
for manual transmission. From quattro GmbH

### Climate control



**Automatic air conditioning**  
electronically regulates the air temperature, flow rate and distribution, with sunlight-dependent control, air intake control and manual recirculation mode, defroster vents for the windscreen and the side windows, dust and pollen filter, humidity sensor, key-coded settings; A5/S5 Cabriolet models have key-coded settings with function for storing two temperatures for when the hood is open and closed

**3-zone deluxe automatic air conditioning**  
with sunlight-dependent control, electronically regulates the air temperature, flow rate and air distribution, separate temperature distribution for driver, front-seat passenger and rear compartment, temperature and air distribution adjustable left and right in the front, control panel in the rear centre console for setting the temperature in the rear compartment, automatic recirculation mode by means of air quality sensor, front control panel features digital display, includes rain, light and humidity sensor, combined/fine particulate filter, indirect ventilation, key-coded settings; A5/S5 Cabriolet models have key-coded settings with function for storing 2 temperatures for when the hood is open and closed

### Auxiliary heating/ventilation

The auxiliary heating heats up the interior and keeps the windows free from ice; the ventilation supplies fresh air and reduces the interior temperature; with timer and separate radio-operated remote control with radio feedback

### Headroom heating

at the front, adjustable in 3 stages, vents on the front-seat backrests

## Luggage securing and storage systems

### Storage compartments

in the front door trims with storage for drinks bottles; for A5/S5 Coupé storage compartments in the rear at the side of the seats and in the side panel trims, eyewear compartment in the front interior lighting module above the interior mirror; additionally for S5 Coupé a storage tray in the centre of the rear bench seat; for A5/S5 Cabriolet storage compartments in the right and left side trim (on right-hand side only if Audi sound system or Bang & Olufsen Sound System are installed), storage nets on the front seat backrests

### Glove compartment

lockable

### Storage package

Storage nets on the backs of the front-seat backrests, storage compartment under the front seats (under the front-passenger seat only if driver's seat has memory function), lockable glove compartment, cup holder in the rear centre armrest

### Cup holders

2, integrated into the centre console

### Cup holders integrated into the rear bench seat

for 2 drinks, with cover and additional storage compartment underneath the front-passenger seat

### Lashing points

4, in luggage compartment, for securing luggage and other objects; for A5/S5 Coupé attachment points for the luggage compartment net



### Luggage compartment package

Luggage compartment net for securing to the lashing points on the luggage compartment floor, net at the side, 12V socket

### Through-loading facility with removable ski/snowboard bag

secured by a strap, for the practical transportation of long objects e.g. up to 4 pairs of skis or 2 snowboards

### Ski/snowboard bag

removable, secured by a strap, for the practical transportation of long items, e. g. up to 4 pairs of skis or 2 snowboards

### Hood compartment, variable

with lowering hood tray. The hood tray lowers automatically when the hood is opened, if sufficient room is available in the luggage compartment. For loading, the hood tray can be lifted when the hood is closed

## Further interior equipment

### Floor mats, front

in velour, coordinated with the carpet colour

### Floor mats, front and rear

in velour, coordinated with the carpet colour

### Audi exclusive floor mats

Individual choice of colour for floor mats and piping from the range of Audi exclusive colours.  
From quattro GmbH

### Audi exclusive carpet and floor mats

Individual choice of colour for carpets, floor mats and piping from the range of Audi exclusive colours.  
From quattro GmbH

### Door sill trims

with aluminium inlays on the door sills; for S5 Coupé/S5 Cabriolet with S5 logo

### Window controls

electric, with safety system to limit closing force, one-touch open/close with convenience function, fixed rear windows; for A5/S5 Cabriolet electric front and rear with safety system to limit closing force, one-touch opening/closing function with central window switch in the centre console

### Cigarette lighter and ashtrays

ashtray in the centre console, front and rear (with A5/S5 Cabriolet only at the front), cigarette lighter integrated in the front ashtray

### Grab handles

cushioned action, folding, two handles recessed into the roof, no grab handles if panoramic tilt sunroof is fitted

### 12V socket

in the side trim of the luggage compartment on the right-hand side at the rear

### 230V socket

in the centre console in the rear; replaces the 12V socket

### Aluminium look in the interior

on light switch, air conditioning, MMI rotary/push-button control, vents, mirror adjustment switch, window controls and around the gear or selector lever gaiter

### Pedals and footrest in aluminium look

underline the sporty character of the S5 Coupé and S5 Cabriolet

## MMI® and navigation systems

**MMI® navigation plus**

- with navigation data (hard drive)<sup>1</sup>
- high-resolution 7-inch colour display with high-quality map representation and topographical map colouring, speed limit display based on navigation data and display of sightseeing information and 3D city models, choice of 3 alternative routes, scrolling along the route
- rotary/push-button control with integrated joystick function for map searches
- split-screen route information (manoeuvring points, points of interest on motorways, TMCpro on route), detailed junction map and lane recommendations, dynamic route guidance with TMCpro (where available)
- for A5/S5 Coupé: voice control system (destination entry by means of whole word input in a sentence)
- read-aloud function for TMCpro reports
- additional arrow display in the driver information system with colour display
- radio with triple tuner and phase diversity
- hard drive can also be used to store music (20 GB)
- MP3, WMA, AAC and MPEG-4 compatible DVD player can also be used for music and video DVDs
- 2 SDHC card readers (for up to 32 GB)
- AUX-IN connection
- 8 passive loudspeakers, total output 80 watts

In conjunction with Audi connect including car phone, it is possible to use services supported by Audi connect, such as navigation using Google Earth™ mapping service<sup>2</sup> and Google Street View™<sup>2</sup>, weather, news and online traffic information.

**MMI® navigation**

- with navigation data (DVD)<sup>1</sup>
- 6.5-inch colour display with high-quality map representation and numerous detailed display options
- for A5/S5 Coupé: voice control (destination entry via spelling)
- dynamic route guidance with TMC (where available)
- MP3 and WMA compatible DVD player for navigation data (DVD), can also be used for music CDs
- additional arrow display in the driver information system (for S5 Coupé/S5 Cabriolet with colour display)
- radio with triple tuner and phase diversity
- 2 SDHC memory card readers (for up to 32 GB)
- AUX-IN connection
- 8 passive loudspeakers, total output 80 watts

**Driver information system**

A monochrome display provides you with information from the trip computer, auto check system, scope of display of the MMI system, brake wear indicator at front, clock and digital speed display; the outside temperature display shows an ice crystal at temperatures under +5°C to warn of possible black ice. The display is also used to indicate the recommended gear in vehicles with manual transmission and on models with automatic transmission when in manual mode. The integrated efficiency program assists you with consumption data overviews, display of additional loads and fuel-saving tips for more economic driving; including attention assist

**Driver information system with colour display**

functions as for driver information system, plus high-resolution colour display and a larger gear display

**Attention assist**

Part of the driver information system; the attention assist analyses driving behaviour using a range of sensors. Steering movements and pedal actuation are recorded, for example, and compared with the individual driving patterns of the respective driver. If the evaluation indicates that the driver's attention is lapsing, the system recommends a break by means of a display in the driver information system and an acoustic signal. The system is active between 65 km/h and 200 km/h and can be deactivated.

## Radio and TV systems



### chorus radio

MMI operating concept with 6.5-inch monochrome display, CD player, 30-station memory with dynamic station list, FM (VHF) and AM (MW, LW) reception; phase diversity, speed-dependent volume control, 8 passive loudspeakers, total output 80 watts. Please note: certain car menu settings cannot be adjusted using the chorus radio

### Digital Audio Broadcasting

In addition to the range of analogue stations, programmes from digitally broadcast radio transmitters with better sound quality can be received according to DAB standard, including DAB+. Display of additional information accompanying the programme (e.g. artist, title, cover) in the form of a slide show and other programme-independent data services (e.g. weather, traffic, news). In connection with MMI navigation or MMI navigation plus also reception of DMB audio, a 2<sup>nd</sup> DAB tuner continuously searches for alternative reception frequencies of the set radio station, at the same time the station list is updated. Please note: reception depends on local digital network availability; contents and scope of the additional information depend on provision by the respective radio section



### concert radio

functions as for chorus radio; plus 6.5-inch colour display, SDHC card reader (up to 32 GB), both MP3, AAC and WMA compatible, TP memo function and AUX-IN connection

### Digital TV reception

Reception of digitally-broadcast (DVB-T), uncoded television stations (MPEG-2 or MPEG-4 standard), DVB-T audio stations, teletext and Electronic Programme Guide (EPG). External AV-IN connection via adapter cable (available through Audi Genuine Accessories). Please note: TV reception depends on digital network availability; no picture possible when the vehicle is moving

### CD changer

in the glove compartment, for 6 CDs (MP3 and WMA compatible), shock-resistant, easily accessible; each CD can be loaded and changed individually. Playback of copy-protected music files (DRM) is not possible.



### symphony radio

functions as for concert radio, plus 6-disc CD changer

### Audi sound system

6-channel amplifier, with a total output of 180 watts, 10 speakers including centre speaker in the dashboard and subwoofer in the parcel shelf (in the left side trim on the A5/S5 Cabriolet)

### Audi music interface

for the connection of portable media players such as Apple iPods from generation 4, Apple iPhone (music functionality) as well as USB storage media and MP3 players. The Audi music interface is located in the glove compartment and operated via the MMI or radio control panel or a leather-covered multifunction steering wheel. Please note: can only be used in conjunction with a special adapter cable (Audi Genuine Accessories). Please contact your Audi partner or visit [www.audi.com/mp3](http://www.audi.com/mp3) for information on compatible media players. (If ordering the Audi music interface, the separate AUX-IN connection is omitted.)

### Adapter cable set for Audi music interface

consisting of 2 connection cables for connecting an iPod/iPhone and data carriers/media players with USB connection (Type A); further adapter cables available from Audi Genuine Accessories. Visit [www.audi.com/mp3](http://www.audi.com/mp3) for information on compatibility.

### Adapter cable set plus for Audi music interface

in addition to the adapter cable set for Audi music interface, it is possible to display cover art and video functions in conjunction with iPhones and the more recent iPod generations; depends on device used; for information on compatibility, visit [www.audi.com/mp3](http://www.audi.com/mp3)

### Radio and TV systems



#### Bang & Olufsen Sound System

surround sound reproduction with 14 loudspeakers (for A5/S5 Cabriolet 12 loudspeakers), including centre speaker in the dashboard and subwoofer in the parcel shelf (in the left side trim on the A5/S5 Cabriolet); 10-channel amplifier with a total output of 505 watts; exclusive speaker covers with aluminium trim; dynamic driving noise compensation. The reproduction of 5.1 Surround Sound is possible in conjunction with MMI navigation plus and the integrated DVD drive.

### Telephone and communication

#### Bluetooth interface

Bluetooth-capable mobile phones can be connected to the vehicle via the interface. Hands-free calls are possible in the vehicle via the microphone; please contact your Audi partner or visit [www.audi.com/bluetooth](http://www.audi.com/bluetooth) for information on compatible mobile phones.

#### Preparation for mobile phone (Bluetooth)

comprises a hands-free facility as well as a fitting for an optional mobile-specific charger in the front centre console; A5/S5 Coupé also has voice control for the telephone functions; includes connection to the vehicle aerial to reduce SAR radiation inside the vehicle and improve reception quality; operated via the navigation systems, concert radio, symphony radio or a multifunction steering wheel (if fitted); please contact your Audi partner or visit [www.audi.com/bluetooth](http://www.audi.com/bluetooth) for adapters and information about which mobile phones are compatible.

#### Bluetooth car phone

Your Bluetooth-capable mobile phone can be conveniently connected to the vehicle's internal UMTS module (provided the mobile phone supports SIM Access Profile); additional SIM card reader in the surround of MMI navigation; transfer of phone book entries to the vehicle and management of call lists; operated via the navigation system or a multifunction steering wheel (if fitted); for information on compatible mobile phones, please contact your Audi partner or visit [www.audi.com/bluetooth](http://www.audi.com/bluetooth).

The model-specific standard and optional equipment can be found in the index from page 130 onwards.

### Telephone and communication



#### Handset, front, for car phone

with colour display and integrated SIM card reader, for private phone calls; easy writing of text messages thanks to automatic word recognition; handset is stored in the front centre armrest

#### Audi connect including car phone

convenient connection of your vehicle to the internet. The use of services supported by Audi connect is possible only with the optional **MMI navigation plus** equipment and with the data module integrated in Audi connect including car phone. You also require a SIM card with a data option – for car phone a SIM card with phone and data option or a Bluetooth-capable smartphone with remote SIM Access Profile (rSAP). There is a reader for your SIM card in the surround of the MMI navigation plus.

The following **services** supported by **Audi connect** are available in your model:

#### Mobility & navigation

- Point-of-interest search (POI); the A5/S5 Coupé also has voice control
- Traffic information online
- Navigation with Google Earth™ map service\* and Google Street View™\*\*
- Destination entry via myAudi or Google Maps™\*\*
- Fuel prices
- Parking information
- Country information

#### Communication

- Wi-Fi hotspot

#### Infotainment

- Weather
- Audi music stream
- News online
- City events
- Travel information

The services are available only with an existing or separate mobile phone contract and only within the range of the respective mobile phone network. Additional costs may be incurred when receiving data packets from the internet, depending on the terms of your mobile phone contract, particularly when used abroad. Because of the high data volumes involved, a data flat rate is strongly recommended.

The availability of the services supported by Audi connect varies from country to country. The services are provided for at least one year from vehicle delivery. The traffic information online service requires initial activation in the vehicle. From that point onwards, this service is subject to a 36-month usage limit (in as far as activation takes place within 6 months of vehicle delivery; otherwise corresponding shortening of the usage rights). Your Audi partner will be happy to inform you about how to extend the service and the costs this incurs.

Please visit [www.audi.com/connect](http://www.audi.com/connect) or contact your Audi partner for more detailed information about Audi connect; contact your mobile services provider for information about contract conditions.

## Assistance systems



### Parking system plus with reversing camera

acoustic and visual parking system for front and rear, image of area behind the vehicle shown on the MMI display, with dynamic display elements showing the calculated path (steer-angle dependent); includes help lines and guidelines and identification of point at which to apply opposite lock when parallel parking, reversing camera integrated discreetly in the handle strip of the luggage compartment lid

### Parking system plus

acoustic and visual park assist system for the front and rear with MMI screen display; measurement is by ultrasonic sensors concealed in the bumpers

### Parking system, rear

working within system limits, makes reverse parking easier by indicating acoustically how far away the vehicle is from a detected object; measurement is by ultrasonic sensors integrated discreetly in the bumpers

### Audi side assist

lane change assistant, working within system limits at speeds of 30 km/h and above, the system uses radar technology to monitor the area on the left, right and behind the moving vehicle and informs or warns the driver by means of an LED display in the respective exterior mirror if Audi side assist has detected another vehicle assessed as critical for lane-changing

### adaptive cruise control

automatic distance control function (control range: 30–200 km/h); working within system limits, it detects vehicles driving ahead with the aid of a radar sensor and maintains this distance by automatic braking and accelerating; 4 distance levels and different driving modes can be selected individually; including Audi pre sense front: Audi braking guard warns the driver through an enhanced brake assist of any imminent threat of collision with the vehicle in front; extended by the function of maximum deceleration: this is initiated at speeds below 30 km/h if there is a danger of collision with a stationary or moving vehicle in order to avoid this collision if possible

### Audi active lane assist

lane compliance assistant, helps the driver within system limits to keep comfortably in lane (operating range from around 60 km/h to 250 km/h). If the system is activated and ready and the driver has not operated the indicators, Audi active lane assist will guide the vehicle within recognised lane boundary lines by means of gentle, corrective steering intervention; the driver can choose whether he would like to be monitored continuously or just shortly before crossing the traffic lane marker (choice of earlier or later steering time); additional steering vibration can be adjusted if the driver wishes

### Assistance package

The assistance package contains the functions of the following assistance systems: parking system plus (upgrade option to parking system plus with reversing camera), Audi active lane assist and adaptive cruise control.

### Hold assist

holds the vehicle stationary for unlimited periods after stopping on normal uphill and downhill gradients. The system is activated by push-button and allows the driver to drive away easily and comfortably.

### Cruise control

At speeds of 30 km/h and above, the system keeps the set speed constant, provided that engine power and engine braking effect permit it; also features active braking intervention, e.g. when driving downhill; operated via separate steering column stalk; set speed displayed in the driver information system

## Suspensions/brakes

### Audi drive select

changes vehicle characteristics e.g. by adapting power steering assistance, accelerator and gear changing characteristics. In addition the system influences other optional equipment; available modes: comfort, auto, dynamic and – in conjunction with an MMI navigation system – individual. The efficiency mode shifts the engine, automatic transmission, climate control and optional adaptive cruise control or cruise control to a consumption-improved basic setting.

### Suspension with damper control

electronically controlled adaptation to different driving situations (S5 Coupé/S5 Cabriolet: on the basis of the S sport suspension); damper characteristics can be adjusted to a dynamic or comfort-oriented setting via Audi drive select

### Dynamic suspension

providing outstanding handling and exceptional ride comfort; 5-link lightweight front axle, tubular cross stabiliser, trapezoidal-link rear axle with independent suspension; twin-tube gas-filled shock absorbers and coil springs, front axle carrier rigidly fixed to the body, flexibly mounted axle supports at rear

### Sport suspension

with stiffer spring and damper tuning for more direct contact with the road and sporty handling

### S line sport suspension

with more dynamic suspension tuning and vehicle lowered by a further 10 mm when compared with the dynamic suspension and the sport suspension

### S sport suspension

with stiffer spring and damper tuning for more direct contact with the road and sporty handling; 5-link lightweight front axle, tubular anti-roll bar, trapezoidal-link rear axle with independent wheel suspension; twin-tube gas-filled shock absorbers and coil springs, front axle carrier rigidly fixed to the body, flexibly mounted axle supports at rear

### Brake system

dual-circuit brake system with diagonally-split brake system, Antilock Brake System (ABS) with Electronic Brake Force Distribution (EBD), Electronic Stabilisation Control (ESC) with brake assist, tandem brake booster, disc brakes front/rear, ventilated at front; S5 Coupé/S5 Cabriolet has high-performance brake system with internally ventilated brake discs on front and rear axles

### Brake callipers

painted in black on the S5 Coupé/S5 Cabriolet, S5 emblem on front callipers

### Electromechanical parking brake

includes parking brake function when stationary, drive-off assistance function through automatic release when driving away and emergency braking function whilst driving acting on all 4 wheels

## Technology/safety

### Body, galvanised

fully-galvanised in areas at risk from corrosion, unitary construction, welded to the floor pan, front and rear areas feature defined crumple zones; (12 year guarantee against rust perforation)

### Airbags

full-size airbags for driver and front-seat passenger; including passenger airbag deactivation switch if ISOFIX child seat mounting for the front-passenger seat is fitted

### Side airbags, front

integrated into the seat backrests

### Side airbags, front and head airbag system

front side airbags integrated into the seat backrests; with additional head airbag system which deploys over the side windows to protect the front and outer rear passengers in the event of a side impact

### Integrated head restraint system

In the event of a rear-end collision, the design of the front seats is better able to restrain the upper torso and provides improved support for the head when compared with conventional systems; this increases the level of protection and reduces the risk of a whiplash injury.

### Active roll-over protection

automatically-triggered protective system behind the rear head restraints

### Seat belts

automatic 3-point belts for all seats, with belt force limiters, seat belt tensioners and seat belt reminder at the front (belt tensioners front and rear for A5/S5 Cabriolet); colour-coordinated with the interior

### Automatic belt presenter

with 2 positions for people of different heights. The belt is automatically moved forward upon activation of the ignition and moved back again after the seat belt has been fastened.

### Instrument cluster

with adjustable lighting, electronic speedometer with odometer and trip odometer, rev counter and automatic ready-check when engine starts, radio-controlled clock (GPS clock in conjunction with MMI navigation plus), coolant temperature display and fuel gauge; for S5 Coupé/S5 Cabriolet with S-specific grey dials, white needles, S5 logo in the rev counter

### Safety steering column

includes a shunt mechanism with damping function to supplement the protection offered by the seat belts and airbags

### First-aid kit

in the storage compartment in the rear centre armrest; for A5/S5 Cabriolet in the storage compartment under the driver seat

### Warning triangle

with bracket on the inside of the luggage compartment lid

### Anti-Slip Regulation (ASR)

for good traction, reduces the spinning of the drive wheels

### Electronic Differential Lock (EDL)

On surfaces with varying levels of grip, this start-off assistant automatically brakes the drive wheels on any surface that is too slippery, thereby ensuring smooth, powerful progress; operates at speeds up to approx. 100 km/h

## Technology/safety

### Electronic Stabilisation Control (ESC)

networks the ABS, EBD, ASR and EDL with its own sensors and compares driving data with reference data; provides better stability at all speeds by targeted braking of individual wheels and intervention in the engine management system

### ESC with electronic axle-differential lock

The electronic axle-differential lock function is integrated in the ESC on front-wheel drive models. It distributes the drive torque by means of targeted braking actions, depending on the driving situation. When cornering, the axle-differential lock actively counteracts understeer. The result is improved traction and dynamic performance when cornering and more precise and neutral handling (less understeer). Agility during steering is also improved.

### Electromechanical power steering

maintenance-free rack & pinion steering with speed-dependent power steering; precise steering feel at high speeds, excellent assistance when parking

### Dynamic steering

When changing lanes, parking and cornering, this system improves comfort and handling by dynamically regulating steering according to the driving situation. In addition to adaptation of the steering effort (as with the electromechanical power steering), the steering angle is also adapted (steering ratio). The system is also supported further by vehicle stabilisation through ESC.

### 6-speed manual transmission

all-synchromesh, hydraulically-actuated dry clutch with asbestos-free linings, 2-mass flywheel

### multitronic®

the multitronic generation of continuously variable transmissions, featuring dynamic gear control program (DCP) and sport program; 8 different gears can be selected in manual mode; hydraulically controlled multi-plate clutch (available for models with front-wheel drive)

### S tronic®

The 7-speed, electrohydraulically actuated dual-clutch transmission facilitates shorter gear changing times and gear changes with virtually no perceptible interruption in the power flow; can be operated via the shift paddles behind the steering wheel (optional, standard with S models) or the selector lever; in automatic mode the driver can choose between the programs D (normal) and S (sport). (Available for models with quattro permanent all-wheel drive)

### Front-wheel drive

Electronic Differential Lock (EDL) through intervention of the braking system on all driven wheels; Anti-Slip Regulation (ASR); Electronic Stabilisation Control (ESC) with brake assist

### quattro®

permanent all-wheel drive with asymmetric/dynamic torque distribution, self-locking centre differential with wheel-selective torque distribution, distributes the driving forces depending on the driving situation to each individual wheel for precisely controlled handling

### quattro® with sport differential

The electronically controlled sport differential distributes variable amounts of driving force to each wheel and ensures outstanding acceleration performance in corners and stabilises the vehicle's response to load change. It also improves direct steering characteristics and provides more agile handling due to the lower steering effort required.

### Start-stop system

helps to reduce fuel consumption and CO<sub>2</sub> emissions by switching off the engine in stationary phases, e.g. at traffic lights. The starting process is initiated as soon as the driver presses the clutch or releases the foot brake for the vehicle to move off again. Can be deactivated at any time via a button.

### Recuperation

Increasing the generator voltage converts kinetic energy into usable electrical energy when the vehicle is coasting or braking. This recovered (braking) energy is used to assist the generator during subsequent acceleration, saving up to 3 % fuel

### Audi TDI clean diesel

In addition to the standard equipment with catalytic converter and diesel particulate filter, the new exhaust aftertreatment system installed in the model with TDI clean diesel leads to low exhaust emissions. Nitrogen oxides are reduced by the innovative nitrogen oxide catalytic converter (DeNOx catalytic converter) at the end of the exhaust pipe. A pump injects tiny quantities of the biologically degradable additive AdBlue®\*. This solution then decomposes in the hot exhaust flow to form ammonia, which splits the nitrogen oxides into nitrogen and water. This splitting is called selective catalytic reduction (SCR). Refill the separate AdBlue® tank as indicated by the information in the display of the instrument cluster. We recommend having the AdBlue tank refilled by your Audi partner (about every 15,000 km).

### Misfuelling protection

mechanically prevents incorrect fuelling of diesel vehicles with petrol

## Audi Extended Warranty

### Audi Extended Warranty

can only be ordered directly and on purchase of a new car; is a consistent continuation of the manufacturer's guarantee so that you are protected against risk and can control servicing costs even after the first 2 years. There is a total of 9 lifetime/total mileage combinations to choose from:

Additional 1 year Audi Extended Warranty, maximum total mileage 30,000 km

Additional 1 year Audi Extended Warranty, maximum total mileage 60,000 km

Additional 1 year Audi Extended Warranty, maximum total mileage 90,000 km

Additional 2 years Audi Extended Warranty, maximum total mileage 40,000 km

Additional 2 years Audi Extended Warranty, maximum total mileage 80,000 km

Additional 2 years Audi Extended Warranty, maximum total mileage 120,000 km

Additional 3 years Audi Extended Warranty, maximum total mileage 50,000 km

Additional 3 years Audi Extended Warranty, maximum total mileage 100,000 km

Additional 3 years Audi Extended Warranty, maximum total mileage 150,000 km

\* Registered trademark of the Verband der Automobilindustrie e. V. (VDA).

## Audi Genuine Accessories: your decision in favour of more individuality.

Have you been able to decide between four excellent vehicles? No matter which one you will be driving shortly – the A5 Coupé, S5 Coupé, A5 Cabriolet or S5 Cabriolet – each of them already has its own particular style. They're just missing one little thing: your personality. The following pages will show you a few of the options available for turning your Audi into the car that meets your requirements. Audi Genuine Accessories are made to match the respective model in design and functionality, enabling you to add your own very personal touches.





Detailed information can be obtained from the Audi A5 accessories catalogue, at [www.audi.com](http://www.audi.com) and from your Audi partner.





1 2

#### 1 Side sill

Emphasises the dynamic side sections and gives the vehicle an individual touch.

#### 2 Rear spoiler

For even more dynamics at the rear: the permanent rear spoiler (painted in body colour in this example).

#### Sports-style tailpipe trims

Made of chrome-plated stainless steel. Available for 4-cylinder models. Colour variants: silver and black. Not for vehicles with factory-fitted tailpipe trims.

#### 3 Snow chains

For improved grip on snow and ice. To fit wheel size 225/50 R 17, for example.

#### 4 Cast aluminium winter wheels in 5-arm design

Complete winter wheel in size 7.5 J x 17 with 225/50 R 17 tyres<sup>1</sup>, can be fitted with snow chains. You can find further wheels in different designs, including summer wheels, in the special accessories catalogue.

#### 5 Luggage compartment tray

The raised lip of the luggage compartment tray protects the luggage compartment against soiling. The non-slip pattern reduces any slipping of the load. The tray is easily stowed away and takes up little space. The rigid luggage compartment liner and rubber floor mats offer even more protection against soiling.

#### 6 Cabriolet care set

For basic care. Contains 300 ml active foam cleaner, 300 ml cloth impregnation agent (for hood and textile covers), insect remover gloves and 1 sponge.

#### 7 Ski and luggage box (450 l)

This lockable ski and luggage box is particularly suitable for winter holiday use. It can be opened and loaded from either side. Suitable for skis up to 2.10 m long. Maximum permissible load of 50 kg must be observed. Further transport options are offered by the cycle mount, cycle fork mount and cycle rack for the trailer towing hitch. Only for the A5 Coupé. (Can only be used in conjunction with the carrier unit.)

#### 8 Adapter cables for Audi music interface<sup>2</sup>

Enables the connection of various iPod™ models and other portable media players. Operation via the MMI system, if this function is supported by the media player.

#### Storage pocket

Practical all-purpose pocket offering versatile storage space to keep the vehicle neat and tidy. Attached to the backrest. Can be easily folded up and taken with you.

<sup>1</sup>You will find specifications on the technical characteristics of tyres on page 127. <sup>2</sup>For more detailed information, please contact your Audi partner.

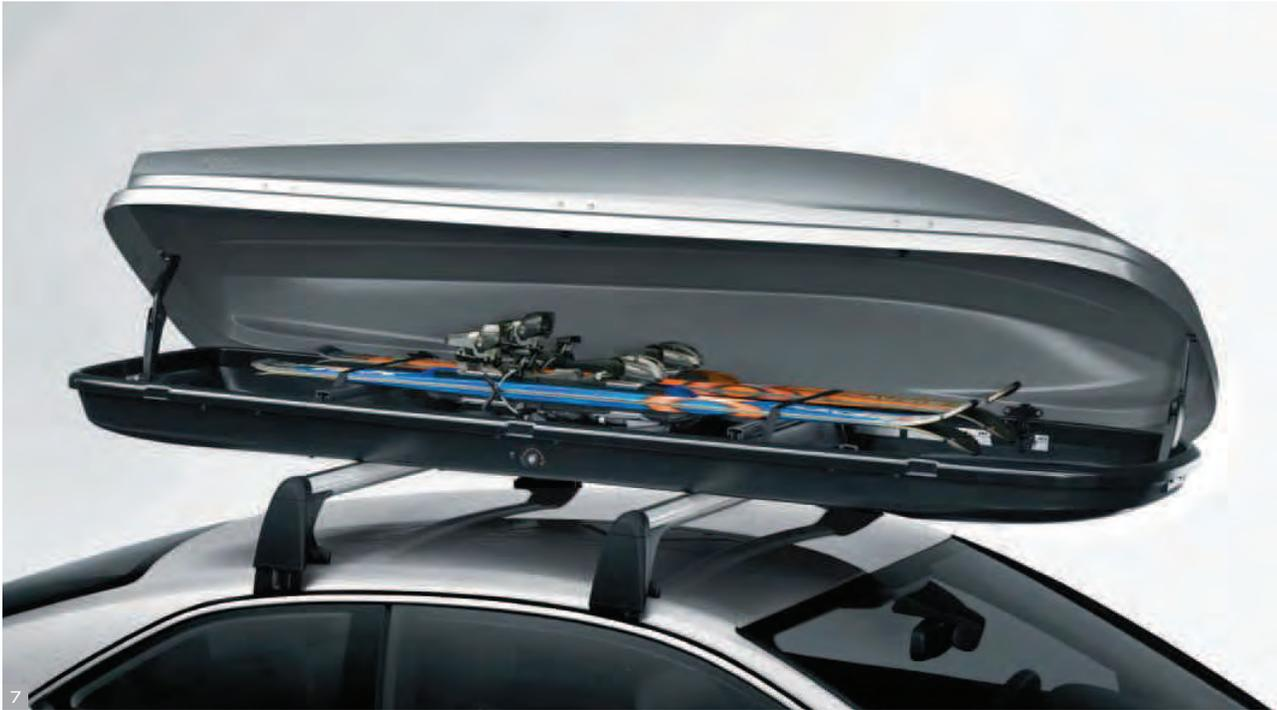

Model		A5 Coupé 1.8 TFSI (125 kW)	A5 Coupé 2.0 TFSI (165 kW)	A5 Coupé 2.0 TFSI quattro (165 kW)	A5 Coupé 3.0 TFSI quattro (200 kW)
Engine type		4-cylinder inline petrol engine with direct fuel injection, turbocharging and Audi valvelift system	4-cylinder inline petrol engine with direct fuel injection, turbocharging and Audi valvelift system	4-cylinder inline petrol engine with direct fuel injection, turbocharging and Audi valvelift system	V6 petrol engine with direct fuel injection and mechanical supercharger module
Displacement in cc (valves per cylinder)		1798 (4)	1984 (4)	1984 (4)	2995 (4)
Max. output <sup>1</sup> in kW at rpm		125/3800-6200	165/4500-6250	165/4500-6250	200/4780-6500
Max. torque in Nm at rpm		320/1400-3700	350/1500-4500	350/1500-4500	400/2150-4780
<b>Power transmission/wheels</b>					
Drive type		Front-wheel drive	Front-wheel drive	quattro® permanent all-wheel drive	quattro® permanent all-wheel drive
Transmission type		6-speed manual transmission [multitronic]	6-speed manual transmission [multitronic]	6-speed manual transmission [7-speed S tronic]	[7-speed S tronic]
Wheels		Forged aluminium wheels, 7.5 J x 17	Forged aluminium wheels, 7.5 J x 17	Forged aluminium wheels, 7.5 J x 17	Cast aluminium wheels, 8.5 J x 18
Tyres		225/50 R 17 <sup>2</sup>	225/50 R 17 <sup>2</sup>	225/50 R 17 <sup>2</sup>	245/40 R 18 <sup>2</sup>
<b>Weights/capacities</b>					
Unladen weight <sup>3</sup> in kg		1500 [1530]	1505 [1550]	1585 [1615]	[1725]
Gross vehicle weight in kg		1925 [1955]	1930 [1975]	2010 [2040]	[2150]
Permissible roof load limit/nose weight in kg		75/80 [75/80]	75/80 [75/80]	75/80 [75/80]	[75/80]
Trailer load limit <sup>4</sup> in kg	unbraked	750 [750]	750 [750]	750 [750]	[750]
	12 % gradient	1500 [1300]	1500 [1500]	1700 [1700]	[1900]
	8 % gradient	1700 [1500]	1700 [1700]	1900 [1900]	[2100]
Fuel tank capacity, approx. in l		63 [63]	63 [63]	[61] [61]	[61]
<b>Performance/consumption<sup>5</sup></b>					
Top speed in km/h		230 [228]	250 <sup>6</sup> [242]	250 <sup>6</sup> [250] <sup>6</sup>	[250] <sup>6</sup>
Acceleration 0-100 km/h in s		7.9 [8.2]	6.8 [6.9]	6.4 [6.4]	[5.8]
Fuel grade		Sulphur-free super RON 95 <sup>7</sup>	Sulphur-free super RON 95 <sup>7</sup>	Sulphur-free super RON 95 <sup>7</sup>	Sulphur-free super RON 95 <sup>7</sup>
Fuel consumption <sup>8</sup> in l/100 km	urban	7.4 [6.9]	7.7 [7.4]	8.8 [8.5]	[10.7]
	extra-urban	4.8 [5.1]	4.8 [5.0]	5.3 [5.6]	[6.6]
	combined	5.7 [5.8]	5.9 [5.8]	6.6 [6.7]	[8.1]
CO <sub>2</sub> emissions <sup>8</sup> in g/ km	urban	173 [160]	180 [171]	203 [197]	[255]
	extra-urban	111 [118]	113 [115]	122 [131]	[154]
	combined	134 [134]	138 [136]	152 [155]	[190]
Emission standard		EU6	EU6	EU6	EU5

[ ] Data in square brackets refer to multitronic or S tronic. Explanation of <sup>1</sup> to <sup>11</sup> on page 127.

Model	A5 Coupé 2.0 TDI (120 kW) <sup>9</sup>	
Engine type	4-cylinder inline diesel engine with common rail injection system and turbocharging	
Displacement in cc (valves per cylinder)	1968 (4)	
Max. output <sup>1</sup> in kW at rpm	120/4200	
Max. torque in Nm at rpm	380/1750–2500	
<b>Power transmission/wheels</b>		
Drive type	Front-wheel drive	
Transmission type	6-speed manual transmission	
Wheels	Forged aluminium wheels, 7.5 J x 17	
Tyres	225/50 R 17 <sup>2</sup>	
<b>Weights/capacities</b>		
Unladen weight <sup>3</sup> in kg	1550	
Gross vehicle weight in kg	1975	
Permissible roof load limit/nose weight in kg	75/80	
Trailer load limit <sup>4</sup> in kg	unbraked	750
	12 % gradient	1300
	8 % gradient	1500
Fuel tank capacity, approx. in l	63	
<b>Performance/consumption<sup>5</sup></b>		
Top speed in km/h	225	
Acceleration 0–100 km/h in s	8.4	
Fuel grade	Sulphur-free diesel <sup>10</sup>	
Fuel consumption <sup>8</sup> in l/100 km	urban	5.4
	extra-urban	3.8
	combined	4.4
CO <sub>2</sub> emissions <sup>8</sup> in g/ km	urban	139
	extra-urban	101
	combined	115
Emission standard	EU5	

#### Audi A5 Coupé 2.0 TDI (120 kW 115 g CO<sub>2</sub>/ km)

This vehicle stands for extra efficiency Audi models. In these models, the balance between performance and consumption has been further improved. These Audi models are characterised by reduced consumption and CO<sub>2</sub> emissions when compared with standard models. This effect has been achieved by modifications to the vehicle.

#### The A5 Coupé 2.0 TDI model (120 kW 115 g CO<sub>2</sub>/ km) is equipped with the following as standard:

- ▶ 6-speed manual transmission with longer ratio between 1<sup>st</sup> and 6<sup>th</sup> gear
- ▶ Driver information system with gear change and efficiency displays; provides gear changing and fuel-saving tips to help the driver adopt a fuel-efficient driving style
- ▶ Fuel-saving tyres with improved rolling resistance
- ▶ Adapted vehicle components for improved aerodynamics and low drag coefficient

#### The A5 Coupé 2.0 TDI (120 kW 115 g CO<sub>2</sub>/ km) is equipped as standard with forged aluminium wheels in 6-arm design, size 7.5 J x 17 with 225/50 R 17 tyres<sup>2</sup>. Optionally, the following wheels are available to you:

- ▶ Cast aluminium wheels in 5-arm design, size 7.5 J x 17 with 225/50 R 17 tyres<sup>2</sup>

#### The following equipment is not available for the A5 Coupé 2.0 TDI (120 kW 115 g CO<sub>2</sub>/ km):

- ▶ Audi active lane assist combined with Audi side assist
- ▶ Trailer towing hitch
- ▶ Through-loading facility with removable ski/snowboard bag
- ▶ Suspension with damper control
- ▶ Slide-and-tilt glass sunroof
- ▶ Climate-controlled comfort seats, front
- ▶ Space-saving spare wheel
- ▶ Vehicle jack
- ▶ Seat heating, front and rear
- ▶ Sunblind, electrically adjustable for the rear window
- ▶ 5 sport seats, front
- ▶ Auxiliary heating/ventilation
- ▶ 230V socket

Model	A5 Coupé 2.0 TDI (130 kW)	A5 Coupé 2.0 TDI quattro (130 kW)	A5 Coupé 3.0 TDI (150 kW)	A5 Coupé 3.0 TDI quattro (180 kW)
Engine type	4-cylinder inline diesel engine with common rail injection system and turbocharging	4-cylinder inline diesel engine with common rail injection system and turbocharging	V6 diesel engine with common rail injection system and turbocharging	V6 diesel engine with common rail injection system and turbocharging
Displacement in cc (valves per cylinder)	1968 (4)	1968 (4)	2967 (4)	2967 (4)
Max. output <sup>1</sup> in kW at rpm	130/4200	130/4200	150/3750–4500	180/4000–4500
Max. torque in Nm at rpm	380/1750–2500	380/1750–2500	400/1250–3500	500/1400–3250
<b>Power transmission/wheels</b>				
Drive type	Front-wheel drive	quattro® permanent all-wheel drive	Front-wheel drive	quattro® permanent all-wheel drive
Transmission type	6-speed manual transmission [multitronic]	6-speed manual transmission [7-speed S tronic]	6-speed manual transmission [multitronic]	6-speed manual transmission [7-speed S tronic]
Wheels	Forged aluminium wheels, 7.5 J x 17	Forged aluminium wheels, 7.5 J x 17	Forged aluminium wheels, 7.5 J x 17	Forged aluminium wheels, 7.5 J x 17
Tyres	225/50 R 17 <sup>2</sup>	225/50 R 17 <sup>2</sup>	225/50 R 17 <sup>2</sup>	225/50 R 17 <sup>2</sup>
<b>Weights/capacities</b>				
Unladen weight <sup>3</sup> in kg	1545 [1570]	1610 [1650]	1615 [1640]	1680 [1715]
Gross vehicle weight in kg	1970 [1995]	2035 [2075]	2040 [2065]	2105 [2140]
Permissible roof load limit/nose weight in kg	75/80 [75/80]	75/80 [75/80]	75/80 [75/80]	75/80 [75/80]
Trailer load limit <sup>4</sup> in kg	unbraked	750 [750]	750 [750]	750 [750]
	12 % gradient	1600 [1700]	1600 [1700]	1900 [1900]
	8 % gradient	1800 [1900]	1800 [1900]	2100 [2100]
Fuel tank capacity, approx. in l	63 [63]	61 [61]	63 [63]	61 [61]
<b>Performance/consumption<sup>5</sup></b>				
Top speed in km/h	230 [225]	228 [225]	244 [235]	250 <sup>6</sup> [250] <sup>6</sup>
Acceleration 0–100 km/h in s	8.2 [7.8]	7.8 [7.8]	7.6 [7.1]	5.9 [5.8]
Fuel grade	Sulphur-free diesel <sup>10</sup>	Sulphur-free diesel <sup>10</sup>	Sulphur-free diesel <sup>10</sup>	Sulphur-free diesel <sup>10</sup>
Fuel consumption <sup>8</sup> in l/100 km	urban	5.5 [5.5]	6.1 [6.4]	6.4 [5.5]
	extra-urban	4.1 [4.3]	4.5 [4.7]	4.3 [4.6]
	combined	4.6 [4.7]	5.1 [5.3]	5.1 [4.9]
CO <sub>2</sub> emissions <sup>8</sup> in g/ km	urban	144 [144]	161 [169]	169 [145]
	extra-urban	106 [111]	119 [122]	113 [121]
	combined	120 [123]	134 [139]	133 [129]
Emission standard	EU5	EU5	EU5	EU5

[ ] Data in square brackets refer to multitronic or S tronic. Explanation of <sup>1</sup> to <sup>11</sup> on page 127.

Model		<b>A5 Coupé 3.0 TDI clean diesel quattro (180 kW)</b> with nitrogen oxide catalytic converter <sup>11</sup>	<b>S5 Coupé (245 kW)</b>
Engine type		V6 diesel engine with common rail injection system and turbocharging	V6 petrol engine with direct fuel injection and mechanical supercharger module
Displacement in cc (valves per cylinder)		2967 (4)	2995 (4)
Max. output <sup>1</sup> in kW at rpm		180/4000–4500	245/5500–6500
Max. torque in Nm at rpm		580/1750–2500	440/2900–5300
<b>Power transmission/wheels</b>			
Drive type		quattro® permanent all-wheel drive	quattro® permanent all-wheel drive
Transmission type		[7-speed S tronic]	[7-speed S tronic]
Wheels		Cast aluminium wheels, 8.5 J x 18	Cast aluminium wheels, 8.5 J x 18
Tyres		245/40 R 18 <sup>2</sup>	245/40 R 18 <sup>2</sup>
<b>Weights/capacities</b>			
Unladen weight <sup>3</sup> in kg		[1770]	[1750]
Gross vehicle weight in kg		[2195]	[2175]
Permissible roof load limit/nose weight in kg		[75/80]	[75/80]
Trailer load limit <sup>4</sup> in kg	unbraked 12 % gradient 8 % gradient	[750] [1900] [2100]	[750] [1900] [2100]
Fuel tank capacity, approx. in l		[61/SCR tank: 20]	[61]
<b>Performance/consumption<sup>5</sup></b>			
Top speed in km/h		[250] <sup>6</sup>	[250] <sup>6</sup>
Acceleration 0–100 km/h in s		[5.9]	[4.9]
Fuel grade		Sulphur-free diesel <sup>10</sup>	Sulphur-free super RON 95 <sup>7</sup>
Fuel consumption <sup>8</sup> in l/100 km	urban extra-urban combined	[6.8] [5.0] [5.7]	[10.7] [6.6] [8.1]
CO <sub>2</sub> emissions <sup>8</sup> in g/ km	urban extra-urban combined	[179] [132] [149]	[250] [154] [190]
Emission standard		EU6	EU5

Model	A5 Cabriolet 1.8 TFSI (125 kW)		A5 Cabriolet 2.0 TFSI (165 kW)		A5 Cabriolet 2.0 TFSI quattro (165 kW)		A5 Cabriolet 3.0 TFSI quattro (200 kW)		
Engine type	4-cylinder inline petrol engine with direct fuel injection, turbocharging and Audi valvelift system		4-cylinder inline petrol engine with direct fuel injection, turbocharging and Audi valvelift system		4-cylinder inline petrol engine with direct fuel injection, turbocharging and Audi valvelift system		V6 petrol engine with direct fuel injection and mechanical supercharger module		
Displacement in cc (valves per cylinder)	1798 (4)		1984 (4)		1984 (4)		2995 (4)		
Max. output <sup>1</sup> in kW at rpm	125/3800-6200		165/4500-6250		165/4500-6250		200/4780-6500		
Max. torque in Nm at rpm	320/1400-3700		350/1500-4500		350/1500-4500		400/2150-4780		
<b>Power transmission/wheels</b>									
Drive type	Front-wheel drive		Front-wheel drive		quattro® permanent all-wheel drive		quattro® permanent all-wheel drive		
Transmission type	6-speed manual transmission [multitronic]		6-speed manual transmission [multitronic]		[7-speed S tronic]		[7-speed S tronic]		
Wheels	Forged aluminium wheels, 7.5 J x 17		Forged aluminium wheels, 7.5 J x 17		Forged aluminium wheels, 7.5 J x 17		Cast aluminium wheels, 8.5 J x 18		
Tyres	225/50 R 17 <sup>2</sup>		225/50 R 17 <sup>2</sup>		225/50 R 17 <sup>2</sup>		245/40 R 18 <sup>2</sup>		
<b>Weights/capacities</b>									
Unladen weight <sup>3</sup> in kg	1695 [1730]		1705 [1735]		[1810]		[1925]		
Gross vehicle weight in kg	2120 [2155]		2130 [2160]		[2235]		[2350]		
Permissible roof load limit/nose weight in kg	-/80 [-/80]		-/80 [-/80]		[-/80]		[-/80]		
Trailer load limit <sup>4</sup> in kg	unbraked	750 [750]		750 [750]		[750]		[750]	
	12 % gradient	1500 [1300]		1500 [1500]		[1700]		[1900]	
	8 % gradient	1700 [1500]		1700 [1700]		[1900]		[2100]	
Fuel tank capacity, approx. in l	63 [63]		63 [63]		[61]		[61]		
<b>Performance/consumption<sup>5</sup></b>									
Top speed in km/h	222 [213]		245 [235]		[240]		[250] <sup>6</sup>		
Acceleration 0-100 km/h in s	8.7 [8.9]		7.4 [7.6]		[7.2]		[6.3]		
Fuel grade	Sulphur-free super RON 95 <sup>7</sup>		Sulphur-free super RON 95 <sup>7</sup>		Sulphur-free super RON 95 <sup>7</sup>		Sulphur-free super RON 95 <sup>7</sup>		
Fuel consumption <sup>8</sup> in l/100 km	urban	7.9 [7.2]		8.1 [7.6]		[8.6]		[11.2]	
	extra-urban	5.1 [5.6]		5.2 [5.3]		[5.9]		[6.9]	
	combined	6.2 [6.2]		6.3 [6.2]		[6.9]		[8.5]	
CO <sub>2</sub> emissions <sup>8</sup> in g/ km	urban	182 [166]		190 [179]		[199]		[262]	
	extra-urban	119 [130]		123 [125]		[136]		[161]	
	combined	143 [143]		148 [145]		[159]		[199]	
Emission standard	EU6		EU6		EU6		EU5		

[ ] Data in square brackets refer to multitronic or S tronic. Explanation of <sup>1</sup> to <sup>11</sup> on page 127.

Model		A5 Cabriolet 2.0 TDI (110 kW)	A5 Cabriolet 2.0 TDI (130 kW)	A5 Cabriolet 2.0 TDI quattro (130 kW)	A5 Cabriolet 3.0 TDI (150 kW)
Engine type		4-cylinder inline diesel engine with common rail injection system and turbocharging	4-cylinder inline diesel engine with common rail injection system and turbocharging	4-cylinder inline diesel engine with common rail injection system and turbocharging	V6 diesel engine with common rail injection system and turbocharging
Displacement in cc (valves per cylinder)		1968 (4)	1968 (4)	1968 (4)	2967 (4)
Max. output <sup>1</sup> in kW at rpm		110/4200	130/4200	130/4200	150/3750–4500
Max. torque in Nm at rpm		320/1750–2500	380/1750–2500	380/1750–2500	400/1250–3500
<b>Power transmission/wheels</b>					
Drive type		Front-wheel drive	Front-wheel drive	quattro® permanent all-wheel drive	Front-wheel drive
Transmission type		6-speed manual transmission	6-speed manual transmission [multitronic]	6-speed manual transmission	[multitronic]
Wheels		Forged aluminium wheels, 7.5 J x 17	Forged aluminium wheels, 7.5 J x 17	Forged aluminium wheels, 7.5 J x 17	Forged aluminium wheels, 7.5 J x 17
Tyres		225/50 R 17 <sup>2</sup>	225/50 R 17 <sup>2</sup>	225/50 R 17 <sup>2</sup>	225/50 R 17 <sup>2</sup>
<b>Weights/capacities</b>					
Unladen weight <sup>3</sup> in kg		1730	1730 [1755]	1795	[1835]
Gross vehicle weight in kg		2155	2155 [2180]	2220	[2260]
Permissible roof load limit/nose weight in kg		-/80	-/80 [-/80]	-/80	[-/80]
Trailer load limit <sup>4</sup> in kg	unbraked	750	750 [750]	750	[750]
	12 % gradient	1600	1600 [1700]	1700	[1900]
	8 % gradient	1800	1800 [1900]	1900	[2100]
Fuel tank capacity, approx. in l		63	63 [63]	61	[63]
<b>Performance/consumption<sup>5</sup></b>					
Top speed in km/h		210	222 [220]	221	[230]
Acceleration 0–100 km/h in s		10.2	8.8 [8.3]	8.5	[7.6]
Fuel grade		Sulphur-free diesel <sup>10</sup>	Sulphur-free diesel <sup>10</sup>	Sulphur-free diesel <sup>10</sup>	Sulphur-free diesel <sup>10</sup>
Fuel consumption <sup>8</sup> in l/100 km	urban	5.6	5.8 [5.8]	6.5	[5.8]
	extra-urban	4.2	4.4 [4.6]	4.9	[4.9]
	combined	4.7	4.9 [5.0]	5.4	[5.2]
CO <sub>2</sub> emissions <sup>8</sup> in g/km	urban	146	150 [152]	168	[153]
	extra-urban	111	114 [121]	127	[129]
	combined	124	127 [132]	142	[138]
Emission standard		EU5	EU5	EU5	EU5

Model	A5 Cabriolet 3.0 TDI quattro (180 kW)	A5 Cabriolet 3.0 TDI clean diesel quattro (180 kW) with nitrogen oxide catalytic converter <sup>11</sup>	S5 Cabriolet (245 kW)
Engine type	V6 diesel engine with common rail injection system and turbocharging	V6 diesel engine with common rail injection system and turbocharging	V6 petrol engine with direct fuel injection and mechanical supercharger module
Displacement in cc (valves per cylinder)	2967 (4)	2967 (4)	2995 (4)
Max. output <sup>1</sup> in kW at rpm	180/4000–4500	180/4000–4500	245/5500–6500
Max. torque in Nm at rpm	500/1400–3250	580/1750–2500	440/2900–5300
<b>Power transmission/wheels</b>			
Drive type	quattro® permanent all-wheel drive	quattro® permanent all-wheel drive	quattro® permanent all-wheel drive
Transmission type	[7-speed S tronic]	[7-speed S tronic]	[7-speed S tronic]
Wheels	Forged aluminium wheels, 7.5 J x 17	Cast aluminium wheels, 8.5 J x 18	Cast aluminium wheels, 8.5 J x 18
Tyres	225/50 R 17 <sup>2</sup>	245/40 R 18 <sup>2</sup>	245/40 R 18 <sup>2</sup>
<b>Weights/capacities</b>			
Unladen weight <sup>3</sup> in kg	[1920]	[1975]	[1955]
Gross vehicle weight in kg	[2345]	[2400]	[2380]
Permissible roof load limit/nose weight in kg	[–/80]	[–/80]	[–/80]
Trailer load limit <sup>4</sup> in kg	unbraked 12 % gradient 8 % gradient	[750] [1900] [2100]	[750] [1900] [2100]
Fuel tank capacity, approx. in l	[61]	[61/ SCR tank: 20]	[61]
<b>Performance/consumption<sup>5</sup></b>			
Top speed in km/h	[250] <sup>6</sup>	[250] <sup>6</sup>	[250] <sup>6</sup>
Acceleration 0–100 km/h in s	[6.3]	[6.3]	[5.4]
Fuel grade	Sulphur-free diesel <sup>10</sup>	Sulphur-free diesel <sup>10</sup>	Sulphur-free super RON 95 <sup>7</sup>
Fuel consumption <sup>8</sup> in l/100 km	urban extra-urban combined	[7.0] [5.2] [5.9]	[11.2] [6.9] [8.5]
CO <sub>2</sub> emissions <sup>8</sup> in g/ km	urban extra-urban combined	[184] [137] [154]	[262] [161] [199]
Emission standard	EU5	EU6	EU5

[ ] Data in square brackets refer to multitronic or S tronic.

## Notes

- <sup>1</sup> The figure given was calculated using the specified measuring procedure (current version of Directive 80/1269/EEC).
- <sup>2</sup> You will find specifications on the technical characteristics of tyres in the adjacent table.
- <sup>3</sup> Unladen vehicle weight includes driver (68 kg), 7 kg of luggage and fuel tank 90 % full, calculated in accordance with the current version of EC Directive 92/21/EEC. Optional equipment may increase the car's unladen weight and drag coefficient, whereupon the possible payload limit and the top speed will be reduced accordingly.
- <sup>4</sup> The engine's power output always decreases with increasing altitude. At 1,000 m above sea level, and for every additional 1,000 m, deduct 10 % from the weight of the outfit (trailer load limit + gross weight of the towing vehicle). Figure for trailer load limit applies to factory-fitted trailer towing hitch. If using the vehicle with a trailer towing hitch for commercial purposes, a digital tachograph may be required under certain conditions.
- <sup>5</sup> A vehicle's fuel consumption and CO<sub>2</sub> emissions do not just depend on how efficiently the vehicle uses the fuel, but are also influenced by driving behaviour and other non-technical factors. CO<sub>2</sub> is the greenhouse gas primarily responsible for global warming.
- <sup>6</sup> Regulated.
- <sup>7</sup> We recommend using sulphur-free super unleaded fuel (95 RON) complying with DIN EN 228. If this is not available, use sulphur-free regular unleaded RON 91 in accordance with DIN EN 228; power output will be slightly reduced. Unleaded RON 95 fuel with a maximum ethanol content of 10 % (E10) can generally be used. Fuel consumption details refer to operation with RON 95 fuel in accordance with 692/2008/EC.
- <sup>8</sup> The figures given were calculated using the specified measuring procedures. The figures do not refer to one individual vehicle and do not form part of any offer, but rather should be used purely for purposes of comparison between the different vehicle models.
- <sup>9</sup> Model with limited range for optional equipment.
- <sup>10</sup> We recommend using sulphur-free diesel in accordance with DIN EN 590. If this is not available, use diesel in accordance with DIN EN 590.
- <sup>11</sup> Refill the separate AdBlue® tank as indicated by the information in the display of the instrument cluster. We recommend having the AdBlue tank refilled by your Audi partner (about every 15,000 km).

## Important note

Inspections are due as shown by the service display.

## Classifications of tyre parameters

The table shows the range of fuel efficiency, wet grip and exterior noise emission classes for the different tyre sizes of the Audi A5 Coupé, A5 Cabriolet, Audi S5 Coupé and S5 Cabriolet.

	Tyre size	Fuel efficiency class	Wet grip class	Exterior noise emission class
Summer tyres	225/50 R 17	F-C	C-B	73-67  - 
	245/45 R 17	F-E	C-B	72-68  - 
	245/40 R 18	F-C	B-A	72-68  - 
	255/35 R 19	F-E	C-A	73-69  - 
	265/30 R 20	E	B	74-68  - 
Winter tyres	225/50 R 17	F-E	E-C	72-68  - 
	245/40 R 18	F-E	E-C	72-68  - 

It is not possible to order a specific tyre. Ask your Audi partner about the range of tyres available in your country.

Audi A5 Coupé

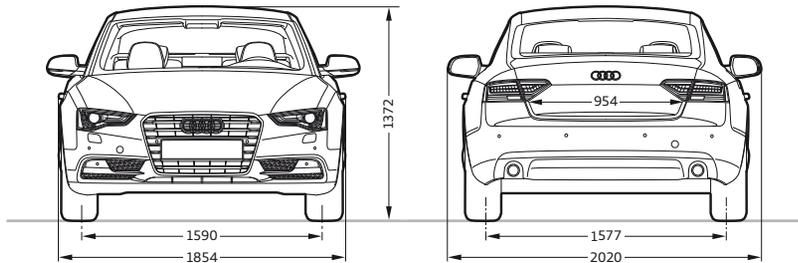
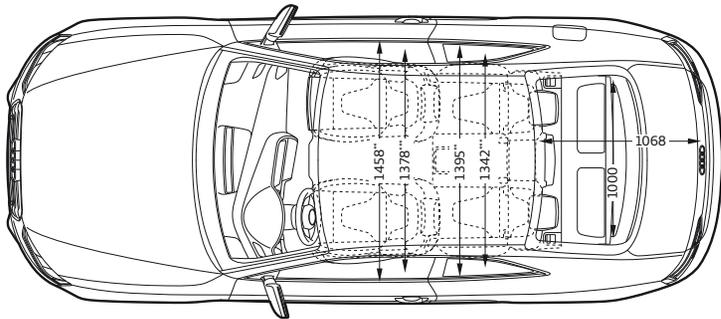
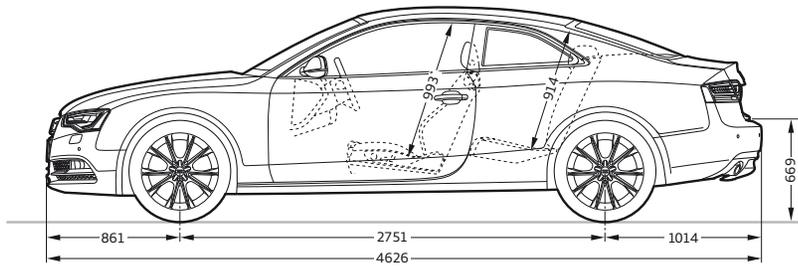

**Dimensions in millimetres.**

Dimensions were measured with vehicle at unladen weight.

Luggage compartment volume 455/829 l (measured by the VDA method, using 200 x 100 x 50 mm blocks; Second value with rear seat backrest folded down).

Turning circle approx. 11.4 m.

\*Maximum headroom. \*\*Elbow room width. \*\*\*Shoulder room width.

Audi S5 Coupé

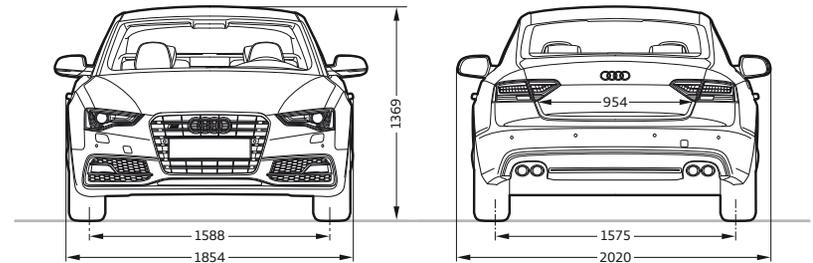
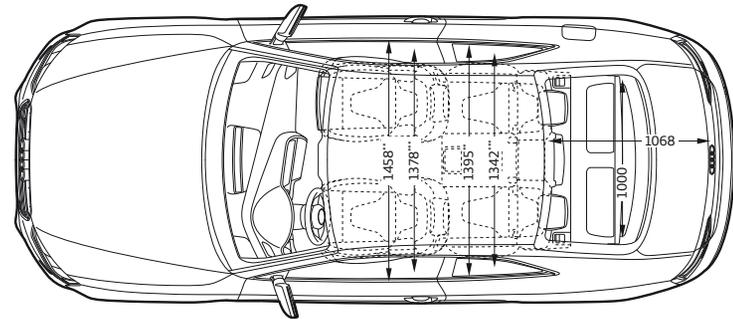
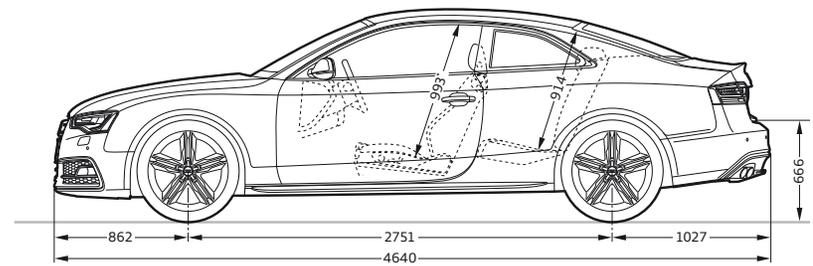

**Dimensions in millimetres.**

Dimensions were measured with vehicle at unladen weight.

Luggage compartment volume 455/829 l (measured by the VDA method, using 200 x 100 x 50 mm blocks; Second value with rear seat backrest folded down).

Turning circle approx. 11.4 m.

\*Maximum headroom. \*\*Elbow room width. \*\*\*Shoulder room width.

### Audi A5 Cabriolet

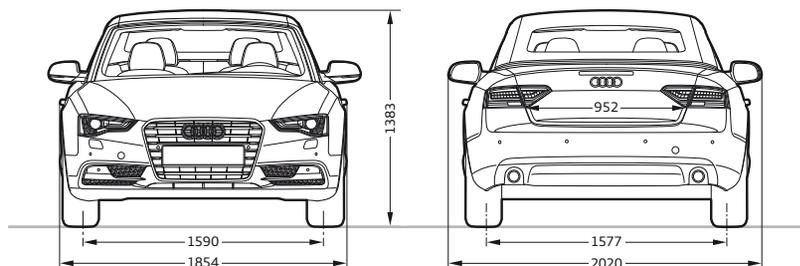
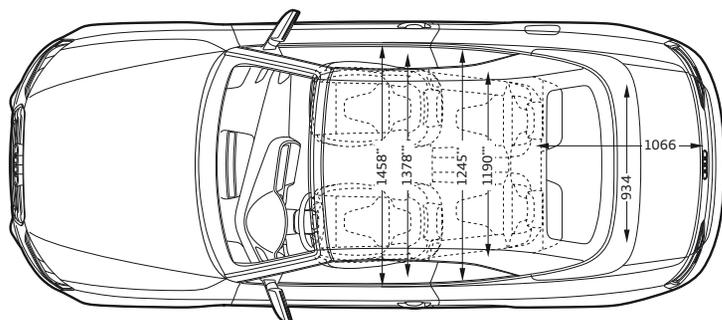
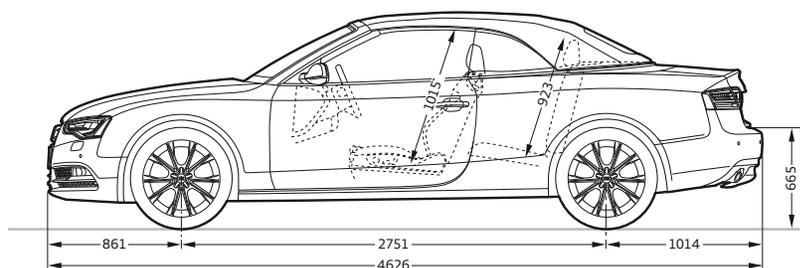

#### Dimensions in millimetres.

Dimensions were measured with vehicle at unladen weight.

Luggage compartment volume 320 l with open hood, 380 l with closed hood, 750 l with the rear seat backrest folded down (measured by the VDA method, using 200 x 100 x 50 mm blocks).

Turning circle approx. 11.4 m.

\* Maximum headroom. \*\* Elbow room width. \*\*\* Shoulder room width.

### Audi S5 Cabriolet

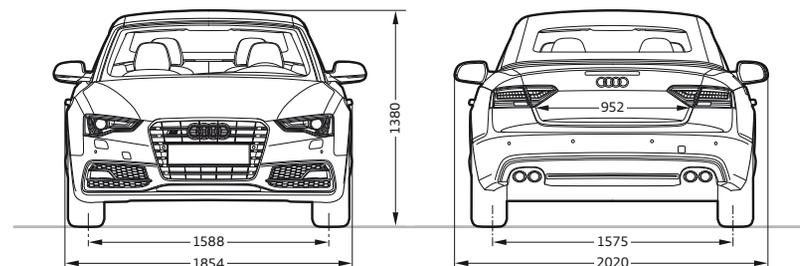
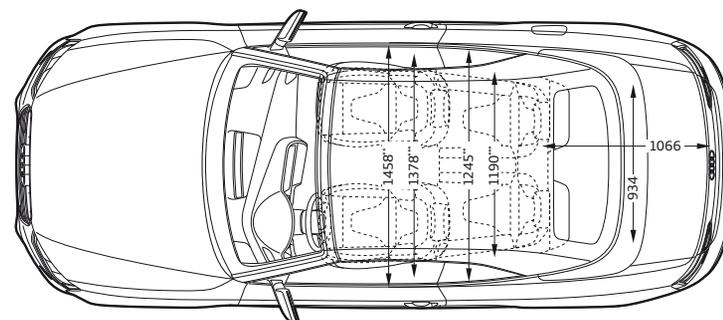
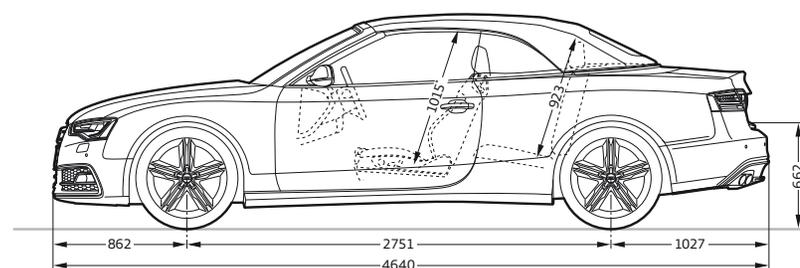

#### Dimensions in millimetres.

Dimensions were measured with vehicle at unladen weight.

Luggage compartment volume 320 l with open hood, 380 l with closed hood, 750 l with the rear seat backrest folded down (measured by the VDA method, using 200 x 100 x 50 mm blocks).

Turning circle approx. 11.4 m.

\* Maximum headroom. \*\* Elbow room width. \*\*\* Shoulder room width.

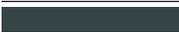
	Page	A5 Coupé	S5 Coupé	A5 Cabriolet	S5 Cabriolet
<b>Equipment packages</b>	<b>78</b>				
Audi exclusive line		■	—	■	—
S line exterior package		■	—	■	—
S line sport package		■	—	■	—
Audi exclusive line for S line sport package		■	—	■	—
<b>Solid paint finishes</b>	<b>88</b>				
 Ibis white		□	□	□	□
 Brilliant red		□	—	□	—
 Brilliant black		□	□	□	□
<b>Metallic paint finishes</b>	<b>88</b>				
 Glacier white, metallic		■	■	■	■
 Ice silver, metallic		■	■	■	■
 Cuvée silver, metallic		■	—	■	—
 Monsoon grey, metallic		■	■	■	■
 Dakota grey, metallic		■	—	■	—
 Teak brown, metallic		■	—	■	—
 Volcano red, metallic		—	■	—	■
 Shiraz red, metallic		■	—	■	—
 Scuba blue, metallic		■	—	■	—
 Moonlight blue, metallic		■	■	■	■
<b>Pearl effect paint finishes</b>	<b>89</b>				
 Misano red, pearl effect		■ <sup>1</sup>	■	■ <sup>1</sup>	■
 Lava grey, pearl effect		■	■	■	■
 Phantom black, pearl effect		■	■	■	■
<b>Crystal effect paint finishes</b>	<b>89</b>				
 Estoril blue, crystal effect		—	■	—	■
<b>Customised paint finishes</b>	<b>89</b>				
 Audi exclusive customised paint finishes		■	■	■	■

□ Standard equipment ■ Optional equipment □■ Standard/optional equipment varies by model — not available

Country-specific variations possible. Please find out from your local Audi partner which equipment is standard and what optional equipment is available in your country.

	Page	A5 Coupé	S5 Coupé	A5 Cabriolet	S5 Cabriolet
<b>Wheels/tyres</b>	<b>90</b>				
 17" forged aluminium wheels in 6-arm design		□ <sup>2</sup>	—	□ <sup>2</sup>	—
 17" cast aluminium wheels in 5-arm design		■ <sup>2</sup>	—	■ <sup>2</sup>	—
 17" cast aluminium wheels in 6-spoke parabola design		■ <sup>2</sup>	—	■ <sup>2</sup>	—
 17" cast aluminium wheels in 7-arm parabola design		■ <sup>2</sup>	—	■ <sup>2</sup>	—
 18" cast aluminium wheels in 5-arm dynamic design		□ <sup>3</sup>	—	□ <sup>3</sup>	—
 18" cast aluminium wheels in 5-V-spoke design		■	—	■	—
 18" cast aluminium wheels in 15-spoke star design		■	—	■	—
 18" cast aluminium wheels in 5-parallel-spoke design (S design)		—	□	—	□

	Page	A5 Coupé	S5 Coupé	A5 Cabriolet	S5 Cabriolet
 18" Audi exclusive cast aluminium wheels in 5-twin-spoke design		■	—	■	—
 18" Audi exclusive cast aluminium wheels in 10-spoke design		■	—	■	—
 18" Audi exclusive cast aluminium wheels in 10-spoke design		■	—	■	—
 19" cast aluminium wheels in 5-arm Y design		■	—	■	—
 19" lightweight wheels in aluminium composite construction, 5-arm Y design, galvano grey metallic, matt		■ <sup>4</sup>	—	■ <sup>4</sup>	—
 19" cast aluminium wheels in 10-spoke design		■	—	■	—
 19" cast aluminium wheels in 5-parallel-spoke star design (S design)		—	■	—	■
 19" Audi exclusive cast aluminium wheels in 5-segment spoke design		■	■	■	■
 19" Audi exclusive cast aluminium wheels in 5-arm rotor design in matt titanium look, high-gloss turned finish		■	■	■	■

	Page	A5 Coupé	S5 Coupé	A5 Cabriolet	S5 Cabriolet
 19" Audi exclusive cast aluminium wheels in 20-spoke design, 2-piece		■	■	■	■
 20" Audi exclusive cast aluminium wheels in 7-twin-spoke design		■	■	■	■
 17" forged aluminium winter wheels in 6-arm design		■ <sup>2</sup>	—	■ <sup>2</sup>	—
 18" cast aluminium winter wheels in 5-V-spoke design		■	—	■	—
 18" cast aluminium winter wheels in 5-parallel-spoke design (S design)		—	■	—	■
Run-flat tyres		■	—	■	—
Anti-theft wheel bolts		■	□	■	□
Tyre repair kit		□	□	□	□
Space-saving spare wheel		■	■	■	■
Tyre pressure loss indicator		■	■	■	■
Vehicle tool kit		□	□	□	□
Vehicle jack		■	■	■	■
<b>Hood colours/hood linings</b>	<b>93</b>				
 Hood, black		—	—	□	□
 Hood, grey		—	—	■	■
 Hood, red		—	—	■	■
 Hood, brown		—	—	■	■
Hood linings		—	—	□	□

<sup>1</sup> Only available in conjunction with S line sport package. <sup>2</sup> Not available for 3.0 TFSI quattro (200 kW) and 3.0 TDI clean diesel quattro (180 kW). <sup>3</sup> Standard for 3.0 TFSI quattro (200 kW) and 3.0 TDI clean diesel quattro (180 kW).

<sup>4</sup> For information on when this feature will be available, please contact your local Audi partner.

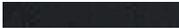
	Page	A5 Coupé	S5 Coupé	A5 Cabriolet	S5 Cabriolet
<b>Seats</b>	<b>94</b>				
Standard seats, front		☐	–	☐	–
Sport seats, front		■	☐	■	☐
S sport seats, front		■ <sup>1</sup>	■	■ <sup>1</sup>	■
Climate-controlled comfort seats, front		■	■	■	■
<b>Seat upholstery for standard seats, front</b>	<b>94</b>				
 Arcade cloth, black		☐	–	☐	–
 Arcade cloth, titanium grey		☐	–	☐	–
 Arcade cloth, velvet beige		☐	–	–	–
 Milano leather, black		■	–	■	–
 Milano leather, titanium grey		■	–	■	–
 Milano leather, velvet beige		■	–	■	–
 Fine Nappa leather, black		■	–	–	–
 Fine Nappa leather, titanium grey		■	–	–	–
 Fine Nappa leather, chestnut brown		■	–	–	–
 Audi exclusive leather upholstery and trim		■	–	■	–
<b>Seat upholstery for sport seats, front</b>	<b>96</b>				
 Atrium cloth, black		■	–	–	–
 Atrium cloth, titanium grey		■	–	–	–
 Alcantara/leather, black		■	☐	■	☐
 Alcantara/leather, lunar silver/black		–	☐	–	☐
 Alcantara/leather, lunar silver		■	–	–	–
 Alcantara/leather, titanium grey		■	–	■	–
 Alcantara/leather combination, velvet beige		–	–	■	–
 Milano leather, black		■	–	■	–
 Milano leather, titanium grey		■	–	■	–

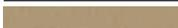
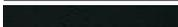
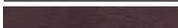
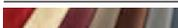
	Page	A5 Coupé	S5 Coupé	A5 Cabriolet	S5 Cabriolet
 Milano leather, velvet beige		■	–	■	–
 Fine Nappa leather, black		■	–	■	–
 Fine Nappa leather, titanium grey		■	–	■	–
 Fine Nappa leather, velvet beige		■	–	■	–
 Fine Nappa leather, lunar silver		■	–	■	–
 Fine Nappa leather, garnet red		■	–	–	–
 Fine Nappa leather, red		–	–	■	–
 Fine Nappa leather, chestnut brown		■	–	■	–
 Fine Nappa leather, Chennai brown		–	–	■	–
 Audi exclusive leather upholstery and trim		■ <sup>2</sup>	■ <sup>2</sup>	■ <sup>3</sup>	■ <sup>3</sup>
<b>Seat upholstery for S sport seats, front</b>	<b>99</b>				
 Fine Nappa leather, black with black stitching		■ <sup>1</sup>	–	■ <sup>1</sup>	–
 Fine Nappa leather, black with contrasting stitching		–	■	–	■
 Fine Nappa leather, lunar silver/black with contrasting stitching		–	■	–	■
 Fine Nappa leather, chestnut brown/black with contrasting stitching		–	■	–	■
 Fine Nappa leather, magma red/black with contrasting stitching		–	■	–	■
 Audi exclusive leather upholstery and trim		■ <sup>4</sup>	■ <sup>2</sup>	■ <sup>5</sup>	■ <sup>3</sup>
<b>Seat upholstery for climate-controlled comfort seats, front</b>	<b>100</b>				
 Perforated Milano leather, black		■	■	■	■
 Perforated Milano leather, titanium grey		■	–	■	–
 Perforated Milano leather, chestnut brown		■	■	■	■
 Perforated Milano leather, velvet beige		■	–	■	–
 Audi exclusive leather upholstery and trim		■	■	■	■
<b>Cloth/leather upholstery and trim</b>	<b>101</b>				
Arcade cloth		☐	–	☐	–
Atrium cloth		■	–	–	–

☐ Standard equipment   ■ Optional equipment   – not available

Country-specific variations possible. Please find out from your local Audi partner which equipment is standard and what optional equipment is available in your country.

	Page	A5 Coupé	S5 Coupé	A5 Cabriolet	S5 Cabriolet
Alcantara/leather combination		■	□	■	□
Milano leather		■	–	■	–
Perforated Milano leather		■	■	■	■
Fine Nappa leather		■ <sup>1</sup>	■	■ <sup>1</sup>	■
Audi exclusive leather upholstery and trim (package 1) in Alcantara/Valcona leather		■	■	–	–
Audi exclusive leather upholstery and trim (package 1) in Valcona leather		■	■	–	–
Audi exclusive leather upholstery and trim (package 2) in Valcona leather		■	■	–	–
Audi exclusive leather upholstery and trim (package 2) in Alcantara/fine Nappa leather		–	–	■	■
Audi exclusive leather upholstery and trim (package 2) in fine Nappa leather		–	–	■	■
<b>Headlinings</b>	<b>101</b>				
Headlining in cloth		□	□	–	–
Headlining in black cloth		■	□	–	–
<b>Inlays</b>	<b>102</b>				
 Reflex finish, steel grey		□	–	□	–
 Reflex finish, moor brown		□	–	□	–
 Matt brushed aluminium		■ <sup>6</sup>	□	■ <sup>6</sup>	□
 Aluminium Trigon		■	–	■	–
 Stainless steel mesh		■ <sup>1</sup>	■	■ <sup>1</sup>	■
 Carbon Atlas		–	■	–	■
 Fine grain birch, grey		■ <sup>1</sup>	■	■ <sup>1</sup>	■
 Walnut, dark brown		■	–	■	–
 Fine grain ash, natural brown		■	–	■	–
 Oak Beaufort, light brown		■	–	■	–
 Aluminium/Beaufort, black		■	■	■	■
 Piano finish, black		■	■	■	■
 Audi exclusive inlays		■	■	■	■

	Page	A5 Coupé	S5 Coupé	A5 Cabriolet	S5 Cabriolet
<b>Lights</b>	<b>104</b>				
Headlights		□	–	□	–
adaptive light		■	■	■	■
Daytime running lights		□	□	□	□
xenon plus		■	□	■	□
Headlight cleaning system		■	□	■	□
High-beam assist		■	■	■	■
LED rear lights		■	□	■	□
Rear lights		□	–	□	–
Interior lighting		□	□	□	□
Lighting package		■	□	■	□
Front fog lights		□	□	□	□
Light/rain sensor		■	■	■	■
<b>Mirrors</b>	<b>105</b>				
Exterior mirrors with integrated LED indicator, electrically adjustable		□	–	□	–
Exterior mirrors, additionally heated		■	□	■	□
Exterior mirrors, additionally heated and electrically folding		■	■	■	■
Exterior mirrors additionally heated, electrically folding and automatically dimming on both sides		■	■	■	■
Exterior mirrors additionally heated, electrically folding and automatically dimming on both sides, with memory function		■	■	■	■
Interior mirror, dimming		□	□	□	□
Interior mirror, automatically dimming		■	■	■	■
<b>Roof systems</b>	<b>105</b>				
Panoramic tilt sunroof		■	■	–	–
Hood		–	–	□	–

<sup>1</sup> Only available in conjunction with S line sport package. <sup>2</sup> Available in Valcona leather and Alcantara/Valcona leather. <sup>3</sup> Available in fine Nappa leather and Alcantara/fine Nappa leather.

<sup>4</sup> Only available in conjunction with S line sport package and in Valcona leather and Alcantara/Valcona leather. <sup>5</sup> Only available in conjunction with S line sport package and in fine Nappa leather and Alcantara/fine Nappa leather.

<sup>6</sup> Only available in conjunction with S line sport package and Audi exclusive line.

	Page	A5 Coupé	S5 Coupé	A5 Cabriolet	S5 Cabriolet
<b>Roof systems (continued)</b>	<b>105</b>				
Acoustic hood		–	–	■	□
Wind deflector		–	–	■	■
<b>Closing systems</b>	<b>105</b>				
Electronic immobiliser		□	□	□	□
Anti-theft alarm		■	■	■	■
Preparation for tracking system		■	■	■	■
Ignition lock		□	□	□	□
Luggage compartment lid, automatically opening		□	□	–	–
Remote control key		□	□	□	□
Convenience key		■	■	■	■
Garage door opener (HomeLink)		■	■	■	■
<b>Glazing</b>	<b>106</b>				
Heat-insulating glass		□	□	□	□
Dark-tinted windows (privacy glazing)		■	■	–	–
Windscreen cleaning system		□	□	□	□
Sun visors		□	□	□	□
Sunblind, electric for the rear window		■	■	–	–
<b>Further exterior equipment</b>	<b>106</b>				
Provision for trailer towing hitch		■	■	■	■
Trailer towing hitch		■	■	■	■
High-gloss package		□	□	–	–
Aluminium-look exterior		–	–	□	□
Audi exclusive black high-gloss package		■	■	–	–
Bumpers, body-coloured (S-specific)		–	□	–	□
Audi Singleframe		□	□	□	□

	Page	A5 Coupé	S5 Coupé	A5 Cabriolet	S5 Cabriolet
Exhaust tailpipes		□	□	□	□
Rear spoiler		–	□	–	–
Model name/logo		□	□	□	□
Sill trims		■*	□	■*	□
<b>Seats/seating comfort</b>	<b>107</b>				
Front seats, electrically adjustable		■	□	■	□
Front seats, electrically adjustable, with memory function for the driver seat		■	■	■	■
4-way lumbar support for the front seats		■	□	■	□
Rear seat backrest, folding		□	□	□	□
Seat heating, front		■	■	■	■
Seat heating, front and rear		■	■	■	■
Heat protection		–	–	□	□
Centre armrest, front		■	□	■	□
Centre armrest, rear		□	□	–	–
Leather-covered armrests in the door trims		■	■	■	■
Head restraints		□	□	□	□
ISOFIX child seat mounting for the rear seats		■	□	□	□
ISOFIX child seat mounting for the front-passenger seat		■	■	■	■
<b>Steering wheels/gear levers/controls</b>	<b>107</b>				
Leather-covered sport steering wheel in 3-spoke design		□	–	□	–
Steering wheel rim in Audi exclusive leather		■	■	■	■
Steering wheel rim with wooden segments		■	–	■	–
Audi exclusive steering wheel rim with wooden segments		■	–	■	–
Leather-covered multifunction sport steering wheel in 3-spoke design		■	□	■	□
Controls in Audi exclusive leather		■	■	■	■
Leather-covered multifunction sport steering wheel in 3-spoke design, flattened at the bottom		■	■	■	■

□ Standard equipment   ■ Optional equipment   – not available

Country-specific variations possible. Please find out from your local Audi partner which equipment is standard and what optional equipment is available in your country.

	Page	A5 Coupé	S5 Coupé	A5 Cabriolet	S5 Cabriolet
Selector lever knob in leather		-	■	-	■
Gear lever knob in Audi exclusive aluminium		■	-	■	-
<b>Climate control</b>	<b>108</b>				
Automatic air conditioning		□	□	□	□
3-zone deluxe automatic air conditioning		■	■	■	■
Auxiliary heating/ventilation		■	■	-	-
Headroom heating		-	-	■	■
<b>Luggage securing and storage systems</b>	<b>109</b>				
Storage compartments		□	□	□	□
Glove compartment		-	-	□	□
Storage package		■	■	-	-
Cup holders		□	□	□	□
Cup holders integrated in the rear bench seat		-	-	■	□
Lashing points		□	□	□	□
Luggage compartment package		■	■	-	-
Through-loading facility with removable ski/snowboard bag		■	■	-	-
Ski/snowboard bag		-	-	■	■
Hood compartment, variable		-	-	□	□
<b>Further interior equipment</b>	<b>109</b>				
Floor mats, front		□	-	□	-
Floor mats, front and rear		■	□	■	□
Audi exclusive floor mats		■	■	■	■
Audi exclusive carpet and floor mats		■	■	■	■
Door sill trims		□	□	□	□
Window controls		□	□	□	□
Cigarette lighter and ashtrays		□	□	□	□

	Page	A5 Coupé	S5 Coupé	A5 Cabriolet	S5 Cabriolet
Grab handles		□	□	-	-
12V socket		-	-	□	□
230V socket		■	■	-	-
Aluminium look in the interior		□	□	□	□
Pedals and footrest in aluminium look		-	□	-	□
<b>MMI® and navigation systems</b>	<b>110</b>				
MMI® navigation plus		■	■	■	■
MMI® navigation		■	■	■	■
Driver information system		□	-	□	-
Driver information system with colour display		■	□	■	□
Attention assist		□	□	□	□
<b>Radio and TV systems</b>	<b>111</b>				
chorus radio		□	□	□	□
Digital Audio Broadcasting		■	■	■	■
concert radio		■	■	■	■
Digital TV reception		■	■	■	■
CD changer		■	■	■	■
symphony radio		■	■	■	■
Audi sound system		■	■	■	■
Audi music interface		■	■	■	■
Adapter cable set for Audi music interface		■	■	■	■
Adapter cable set plus for Audi music interface		■	■	■	■
Bang & Olufsen Sound System		■	■	■	■

\*Only available in conjunction with S line exterior package.

	Page	A5 Coupé	S5 Coupé	A5 Cabriolet	S5 Cabriolet
<b>Telephone and communication</b>	<b>112</b>				
Bluetooth interface		■	■	■	■
Preparation for mobile phone (Bluetooth)		■	■	■	■
Bluetooth car phone		■	■	■	■
Handset, front, for car phone		■	■	■	■
Audi connect including car phone		■	■	■	■
<b>Assistance systems</b>	<b>113</b>				
Parking system plus with reversing camera		■	■	■	■
Parking system plus		■	■	■	■
Parking system, rear		■	■	■	■
Audi side assist		■	■	■	■
adaptive cruise control		■	■	■	■
Audi active lane assist		■	■	■	■
Assistance package		■	■	■	■
Hold assist		■	■	■	■
Cruise control		■	■	■	■
<b>Suspensions/brakes</b>	<b>114</b>				
Audi drive select		■	■	■	■
Suspension with damper control		■	■	■	■
Dynamic suspension		□	–	□	–
Sport suspension		■	–	■	–
S line sport suspension		■	–	■	–
S sport suspension		–	□	–	□
Brake system		□	□	□	□
Brake callipers painted in black, S5 emblem on front callipers		–	□	–	□
Electromechanical parking brake		□	□	□	□

	Seite	A5 Coupé	S5 Coupé	A5 Cabriolet	S5 Cabriolet
<b>Technology/safety</b>	<b>114</b>				
Body, galvanised		□	□	□	□
Airbags		□	□	□	□
Side airbags, front		–	–	□	□
Side airbags, front and head airbag system		□	□	–	–
Integrated head restraint system		□	□	□	□
Active roll-over protection		–	–	□	□
Seat belts		□	□	□	□
Automatic belt presenter		–	–	□	□
Instrument cluster		□	□	□	□
Safety steering column		□	□	□	□
First-aid kit		■	■	■	■
Warning triangle		■	■	■	■
Anti-Slip Regulation (ASR)		□	□	□	□
Electronic Differential Lock (EDL)		□	□	□	□
Electronic Stabilisation Control (ESC)		□	□	□	□
ESC with electronic axle-differential lock		□ <sup>1</sup>	–	□ <sup>1</sup>	–
Electromechanical power steering		□	□	□	□
Dynamic steering		■	■	■	■
6-speed manual transmission		□	–	□	–
multitronic®		■ <sup>1</sup>	–	■ <sup>1</sup>	–
S tronic®		□ <sup>2</sup>	□	□ <sup>2</sup>	□
Front-wheel drive		□	–	□	–
quattro®		■	□	■	□

□ Standard equipment   ■ Optional equipment   □■ Standard/optional equipment varies by model   – not available

Country-specific variations possible. Please find out from your local Audi partner which equipment is standard and what optional equipment is available in your country.

	Seite	A5 Coupé	S5 Coupé	A5 Cabriolet	S5 Cabriolet
quattro® with sport differential		■ <sup>3</sup>	■	■ <sup>3</sup>	■
Start-stop system		□	□	□	□
Recuperation		□	□	□	□
Audi TDI clean diesel		□ <sup>4</sup>	—	□ <sup>4</sup>	—
Misfuelling protection		■ <sup>5</sup>	—	■ <sup>5</sup>	—
<b>Audi Extended Warranty</b>	<b>115</b>				
Audi Extended Warranty		■	■	■	■

Equipment for the Audi A5 Coupé illustrated (p. 4–19):

Paint finish: ice silver, metallic;

Wheels: cast aluminium wheels in 10-spoke design;

Seats/seat upholstery: sport seats, front, in fine Nappa leather, lunar silver;

Inlays: aluminium Trigon

Equipment for the Audi S5 Coupé illustrated (p. 20–31):

Paint finish: ice silver, metallic

Wheels: cast aluminium wheels in 5-parallel-spoke star design (S design)

Seats/seat upholstery: S sport seats, front, in fine Nappa leather in lunar silver/black with contrasting stitching

Inlays: stainless steel mesh

Equipment for the Audi A5 Cabriolet illustrated (p. 32–43):

Paint finish: teak brown, metallic

Wheels: cast aluminium wheels in 5 V-spoke design

Seats/seat upholstery: climate-controlled comfort seats, front, in perforated Milano leather, velvet beige, with moor brown interior equipment

Inlays: fine grain ash, natural brown

Equipment for the Audi S5 Cabriolet illustrated (p. 44–55):

Paint finish: ibis white;

Wheels: cast aluminium wheels in 5-parallel-spoke star design (S design)

Seats/seat upholstery: S sport seats, front, in fine Nappa leather, magma red/black with contrasting stitching

Inlays: matt brushed aluminium

<sup>1</sup> Only available for models with front-wheel drive. <sup>2</sup> Only available for models with quattro permanent all-wheel drive. <sup>3</sup> Only available for 3.0 TDI quattro (180 kW) and 3.0 TFSI quattro (200 kW).

<sup>4</sup> Only available for 3.0 TDI clean diesel quattro (180 kW). <sup>5</sup> Only available for diesel models.

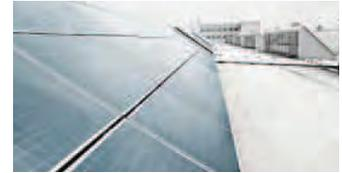
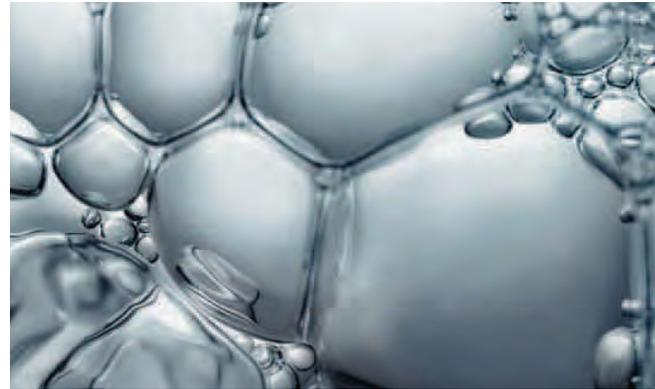

# Discover



## The Audi experience

The fascination of Audi can be experienced in many different ways. Audi City in London, for example, gives you digital access to all models at their actual size and in real time. And of course it is always worth visiting one of the major motor shows. This is where Audi always presents its new models and invites you to take a look at how the future is being shaped with "Vorsprung durch Technik". Anyone interested in seeing how Audi is already putting this into practice will find fascinating insight in the "Vorsprung durch Technik" online special at [www.audi.com](http://www.audi.com). But a look back can also be rewarding:

at the Audi mobile museum in Ingolstadt, history and high-tech go hand in hand. A total of 130 historic exhibits and state-of-the-art forms of presentation make for a thrilling symbiosis. Plus, Audi driving experience allows you to live the excitement and countless possibilities of current Audi models. Here, pure driving enjoyment is combined with valuable learning effects. This is ensured by a team of specially trained and highly qualified instructors who provide practical tips to help you optimise your driving skills.





## Responsibility

Living up to our responsibilities is a principle that is firmly anchored in Audi strategy. Alongside commercial success and international competitiveness, our responsibility toward company employees and society as a whole is a key consideration, as is protecting the environment and conserving resources. And what is true in the details – our catalogues are printed on FSC-certified paper – also holds in general: Audi develops cars that are not only sporty and emotive but also ever more efficient. In the long run, Audi wants its products to allow CO<sub>2</sub>-neutral

mobility. Seeing to it that production in Audi plants gradually becomes CO<sub>2</sub>-neutral is another aspect of our comprehensive approach. Audi is also committed to society – particularly in the fields of education, technology and social projects. At Audi, sustainability is closely linked with how we see the future: the Audi Urban Future Initiative sees Audi working with international experts to get to the root of future urban challenges and trends in mobility.

# the world of Audi.



Choosing an Audi means choosing a brand that offers more. More individuality. More exclusivity. More fascination.



## Team spirit

Motorsport is a driving force behind the brand. For years Audi has been among the champions in various racing series, for instance the 24 Hours of Le Mans or the DTM German Touring Car Masters. The values that are crucial in many different areas of sports are also central ones for Audi: precision, passion and technology. No coincidence then that Audi has been sponsoring

sporting events for many years. In the world of winter sports, for example, Audi has been the main sponsor of the German Ski Association (DSV) for almost three decades and has also partnered 14 other national alpine teams. In football, we support national and international teams. And Audi is also a partner for the German Olympic Sports Confederation.

## www.audi.com

Information on all subjects mentioned can be found on our website: [www.audi.com](http://www.audi.com).

 [www.audi.com](http://www.audi.com)

 [www.audi.com/driving](http://www.audi.com/driving)

 [configurator.audi.com](http://configurator.audi.com)

 [www.audi.com/cr](http://www.audi.com/cr)

 [www.audi.com/vorsprung-durch-technik](http://www.audi.com/vorsprung-durch-technik)



**AUDI AG**  
85045 Ingolstadt  
www.audi.com  
Valid from April 2013

Printed in Germany  
333/1130.52.18

The models and equipment versions illustrated and described in this brochure and some of the services listed are not available in all countries. Some of the cars illustrated are equipped with optional features for which an extra charge is made. Details concerning the delivery specifications, appearance, performance, dimensions and weights, fuel consumption and running costs of the vehicle were correct to the best of our knowledge at the time of going to press. Deviations from the colours and shapes shown in the illustrations may occur. No liability is accepted for errors and printing errors. The right to introduce modifications is reserved. Not to be reproduced, including in part, without the written approval of AUDI AG.

This brochure is printed on paper made from pulp bleached without the use of chlorine.

